

**Regular Meeting of the Barre City Council
Held March 24, 2020**

The Regular Meeting of the Barre City Council was called to order in person by Mayor Lucas Herring at 7:00 PM at Barre City Hall. In attendance, participating via video or phone conference, were: From Ward I, Councilors Jake Hemmerick and John Steinman; from Ward II, Councilors Michael Boutin and Teddy Waszazak; and from Ward III, Councilors Rich Morey and Ericka Reil. Also present via video or phone conference were City Manager Steve Mackenzie, Public Works Director Bill Ahearn, Finance Director Dawn Monahan, and Clerk/Treasurer Carol Dawes.

Absent: NONE

Absent: NONE

Adjustments to the Agenda: Manager Mackenzie asked to add a COVID-19 update under old business. Such an update will be included on the weekly agendas until further notice. Councilor Hemmerick asked that the COVID-19 update include a discussion on frequency of financial reporting updates.

Approval of Consent Agenda:

Council approved the following consent agenda items on motion of Councilor Morey, seconded by Councilor Boutin. **Motion carried on roll call vote, with all voting in favor.**

- Minutes of the following meetings:
 - Regular Meeting of March 17, 2020
- City Warrants as presented:
 - Approval of Week 2020-12:
 - Accounts Payable: \$153,630.71
 - Payroll (gross): \$139,858.76
 - 2020 Licenses: NONE

The City Clerk/Treasurer Report – Clerk/Treasurer Dawes reported on the following:

- The Clerk’s office is closed to the public, but staff is providing service via phone, web and email. Water & sewer bills, taxes, dog licenses and parking tickets can be paid on-line through a link on the City website. All bills and fees can also be paid by mail, or dropped in the drop box next to the front door of City Hall.
- Dog licenses are available, and the deadline has been extended from April 1st to May 1st.
- Water/sewer bills are due by March 31st. However, no late fees or interest charges will accrue during the month of April on any delinquent water/sewer bill.
- No late fees or interest charges will accrue on delinquent property tax bills from March 18th – April 15th.

Liquor Control – NONE

City Manager’s Report - Manager Mackenzie reported on the following:

- Will bring to Council for approval next week an interim policy regarding parking meters and enforcement under the current emergency circumstances.
- Negotiations are ongoing for the municipal pool project. The Manager said moving forward with both the base project and the beach entry will likely require reallocation of funds in the \$1.7 million bond approved by voters at the March 3, 2020 annual town meeting. He asked for input from Councilors. After a brief discussion, Council voiced support to continue with the negotiations and possible reallocation of funds.

Visitors and Communications – NONE

Old Business –

A) Approval of Authorization to Conduct Tax Sales.

Clerk Dawes said this is an annual authorization approved by Council to conduct tax sales during the year. In light of the virtual Council meeting, the Clerk asked that the approval include authorizing Mayor Herring to sign the authorization on behalf of the Council. Council approved the authorization and empowered the Mayor to sign on behalf of the Council on motion of Councilor Boutin, seconded by Councilor Reil. **Motion carried on roll call vote with all voting in favor.**

B) Ratify Council Actions re. COVID-19 Response: Dog Licenses, Parking Permits, Delinquent Bills Interest and Late Fees.

Clerk Dawes reminded Council of last week's actions, when the Council approved extending the dog license late fees to May 1st, allowing those with overnight parking permits to park during the day through April 3rd, and waiver of late fees and interest charges for thirty days on delinquent water & sewer bills and property tax payments. Council ratified last week's actions on motion of Councilor Waszazak, seconded by Councilor Hemmerick. **Motion carried on roll call vote with all voting in favor.**

New Business –

A) Authorization to Accept FY20 GHSP eticket subgrant for Barre City PD.

Council approved accepting the grant on motion of Councilor Steinman, seconded by Councilor Hemmerick. **Motion carried on roll call vote with all voting in favor.**

B) Authorization to Apply for the SRF loan for WWTF Improvements.

Public Works Director Bill Ahearn said the loan will cover costs associated with design and engineering services for the wastewater treatment facility improvements project. If construction is completed, the loan will be forgiven. The project involves replacing one digester cover, the boiler, and gas flare.

Council approved the application on motion of Councilor Morey, seconded by Councilor Boutin. **Motion carried on roll call vote with all voting in favor.**

C) Authorization to Execute Step II DuBois & King, Inc. Design Phase Agreement for WWTF Improvements.

Manager Mackenzie said the agreement with Dubois & King is the design and engineering services covered by the SRF loan approved in the previous agenda item. The cost of the agreement is equal to the value of the loan. There was discussion on the bid process, and it was noted Dubois & King was previously selected through a qualified bid selection more than a year ago.

Council approved execution of the agreement on motion of Councilor Steinman, seconded by Councilor Reil. **Motion carried on roll call vote with all voting in favor.**

D) Authorization to Purchase DPW Truck Chassis.

DPW Director Ahearn said this item will be covered out of the \$1.7 million bond recently approved by the voters. It has been selected for first purchase out of the items included in the bond because of a favorable state price and availability.

Council approved the purchase on motion of Councilor Waszazak, seconded by Councilor Morey. **Motion carried on roll call vote with all voting in favor.**

Added) COVID-19 Response Update, Discussion and/or Action.

Manager Mackenzie said Governor Scott just issued his "Stay at Home" order late this afternoon, and the

staff will look to implement its plans for compliance. There has been discussion on work at home options and what services are essential. In an effort to reduce the need for staff time in the offices, all payroll is being transitioned to direct deposit. All playgrounds and recreation facilities are closed. An interim purchase order process has been implemented for purchases over \$500. The Manager said Finance Director Dawn Monahan has been working on revised FY20 end-of-year projections, based on potential lost revenues due to the COVID-19 response. Preliminary projections show a year-end deficit of approximately \$400,000. The Manager said he will have a draft payroll policy next week.

Councilor Hemmerick requested more frequent financial reports, especially during the COVID-19 situation. He requested monthly updates. Manager Mackenzie said the intention is to present an update at next week's meeting.

Councilor Morey asked to hear from the Police Department about what safety measures are being taken by officers during interactions with the public.

Round Table –

Councilor Reil asked people with disabilities to reach out to local disability services during the COVID-19 situation.

Councilors reminded the public to remember those who are isolated, to offer support to our neighbors, practice social distancing, and support local businesses.

Mayor Herring reviewed the agenda for next week, and reminded people to go to trusted sources for COVID-19 updates. The Mayor said in light of current virtual meetings, the Council will review the policy and procedures for meetings.

Executive Session – NONE

The Council meeting adjourned at 8:06 PM on motion of Councilor Reil, seconded by Councilor Boutin. **Motion carried on roll call vote, with all voting in favor.**

There is no audio recording of this meeting. The meeting was recorded by the video conference platform.

Respectfully submitted,

Carolyn S. Dawes, City Clerk

**Special Meeting of the Barre City Council
Held March 17, 2020**

The Special Meeting of the Barre City Council was called to order in person by Mayor Lucas Herring at 6:16 PM at Barre City Hall. In attendance, participating via conference phone call, were: From Ward I, Councilors Jake Hemmerick and John Steinman; from Ward II, Councilor Michael Boutin; and from Ward III, Councilor Ericka Reil. Also present in person was City Manager Steve Mackenzie.

Absent: From Ward II, Councilor Teddy Waszazak; and from Ward III, Councilor Rich Morey.

Adjustments to the Agenda: NONE

Executive Session –

Councilor Boutin made the motion to find that premature general public knowledge of negotiation and contract issues to be discussed would clearly place the City of Barre at a substantial disadvantage should the discussion be public. The motion was seconded by Councilor Reil. **Motion carried on roll call vote, with all voting in favor.**

Council went into executive session at 6:18 PM to discuss negotiations and contracts under the provisions of 1 VSA § 313 on motion of Councilor Steinman, seconded by Councilor Boutin. **Motion carried on roll call vote, with all voting in favor.**

Manager Mackenzie and Public Works Director Bill Ahearn were invited into the executive session.

Council came out of executive session at 6:34 PM on motion of Councilor Steinman, seconded by Councilor Boutin. **Motion carried on roll call vote, with all voting in favor.**

The Council meeting adjourned at 6:35 PM on motion of Councilor Boutin, seconded by Councilor Reil. **Motion carried on roll call vote, with all voting in favor.**

There is no audio recording of this meeting.

**Regular Meeting of the Barre City Council
Held March 10, 2020**

The Regular Meeting of the Barre City Council was called to order in person by Mayor Lucas Herring at 7:00 PM at Barre City Hall. In attendance, participating via conference phone call, were: From Ward I, Councilors Jake Hemmerick (joined 7:10 PM) and John Steinman; from Ward II, Councilor Michael Boutin; and from Ward III, Councilor Ericka Reil. Also present in person were City Manager Steve Mackenzie and Clerk/Treasurer Carol Dawes.

Absent: From Ward II, Councilor Teddy Waszazak; and from Ward III, Councilor Rich Morey.

Absent: NONE

Adjustments to the Agenda: NONE

Approval of Consent Agenda:

Council approved the following consent agenda items on motion of Councilor Boutin, seconded by Councilor Reil. **Motion carried on roll call vote, with all voting in favor.**

To be approved at 03-17-20 Barre City Council Meeting

- Minutes of the following meetings:
 - Regular Meeting of March 10, 2020
- City Warrants as presented:
 - Approval of Week 2020-11:
 - Accounts Payable: \$214,134.25
 - Payroll (gross): \$122,380.46
 - 2020 Licenses: NONE

The City Clerk/Treasurer Report – Clerk/Treasurer Dawes reported on the following:

- The Clerk’s office has put measures in place to limit the public’s need to come to the office. Water & sewer bills, taxes, dog licenses and parking tickets can be paid on-line through a link on the City website. There is a convenience fee for use of the on-line system. All bills and fees can also be paid by mail, or dropped in the drop box next to the front door of City Hall.
- Dog licenses are available.
- Water/sewer bills are due by March 31st.

Liquor Control – NONE

City Manager’s Report - Manager Mackenzie reported on the following:

- There was a major water main break earlier today at the junction of Allen and Prospect Streets. The break has been repaired and full water service restored. A boil water notice has been issued for all water service customers, and will remain in place until required testing is complete.
- The municipal pool project bids came in higher than anticipated. Staff is hoping to move into competitive negotiations with the two low bidders to ensure the project can still include the base project and beach entry. The splash park is off the table.

Visitors and Communications – NONE

Old Business – NONE

New Business –

A) Appointment of Jeffrey Tuper-Giles to the Public Art Committee.

Council appointed former Councilor Jeffrey Tuper-Giles to the committee on motion of Councilor Boutin, seconded by Councilor Steinman. **Motion carried on a roll call vote, with all voting in favor.**

B) Update and/or Action Regarding COVID-19.

Manager Mackenzie reviewed the steps being taken to address COVID-19 issues, and noted the City is maintaining a section devoted to the topic on the website, along with links to the VT Department of Health and the Centers for Disease Control websites. Department heads are holding thrice-weekly conference calls to stay updated on the City’s response, with Fire Chief Doug Brent and Deputy Chief Joe Aldsworth as the lead contacts. All inspections are on hold unless determined to be required for public safety, and issuance of burn permits is suspended. The City will be hosting a telephone town hall this Thursday evening, where the public can call in with questions.

Councilor Reil asked if an interpreter can be provided for the town hall. Manager Mackenzie will see if that’s a possibility. Councilor Hemmerick asked if the City is tracking expenses associated with the virus response, in case there is future state or federal funding available. Manager Mackenzie said he will discuss such tracking with Finance Director Dawn Monahan.

Clerk Dawes said the City has expanded on-line payment options to include current & delinquent taxes,

current & delinquent water and sewer bills, dog licenses, and parking tickets. The Clerk recommended the following actions:

1. Change the dog licensing deadline from April 1st to May 1st.
2. Close the current water & sewer billing cycle on March 31st as usual, but waive late fees or interest through the month of April, for both the current bills and delinquent bills.
3. Waive additional late fees and interest on all delinquent tax bills from March 17 through April 15.

Council approved the recommendations on motion of Councilor Boutin, seconded by Councilor Steinman. **Motion carried on roll call vote, with all voting in favor.**

Clerk Dawes asked Council to allow those with overnight parking permits to park during the day without additional permits required. The Clerk said this would accommodate those who live in the downtown and have overnight permits, but usually leave the City during the day to go to work. Some of them are now self-quarantined at home. Council approved expanding overnight permits to 24 hours through April 3rd on motion of Councilor Boutin, seconded by Councilor Steinman. **Motion carried on roll call vote, with all voting in favor.**

Clerk Dawes said she would place all voted items above on next week's agenda for ratification, as they were not warned for action at this meeting.

Clerk Dawes reviewed her memo outlining possible scenarios around limiting public access to or closing City Hall. Council voiced support for whatever actions the Manager and Clerk think would be appropriate to protect the staff and public.

C) Authorize Submission of USDA Teen Center Grant Application.

Mayor Herring said the application is for up to \$40,000 for the construction of an accessible ramp on the rear of the Wheelock building. Council approved submission on motion of Councilor Steinman, seconded by Councilor Reil. **Motion carried on roll call vote, with all voting in favor.**

D) Approval of Authorization to Conduct Tax Sales.

Clerk Dawes said the document had not been included in the Council packet, and asked to defer this to next week.

E) Ratify Manager's Execution of FY21 Propane Supply Contract with Irving Energy.

Council ratified the Manager's contract execution on motion of Councilor Steinman, seconded by Councilor Hemmerick. **Motion carried on roll call vote, with all voting in favor.**

F) Ratify Manager's Execution of FY21 #2 Fuel Oil Supply Contract with Dead River.

Council ratified the Manager's contract execution on motion of Councilor Hemmerick, seconded by Councilor Steinman. **Motion carried on roll call vote, with all voting in favor.**

G) Policy Work Group Updates.

Mayor Herring said Councilor groups continue to review policies. The Mayor will update the information on the Council priority list, which will come back to Council for review in May.

Round Table –

Councilors urged people to be safe in the face of the COVID-19 virus, and reminded people of social distancing and hand washing.

Councilor Hemmerick said he appreciates the work being done by public employees in the face of the virus.

To be approved at 03-17-20 Barre City Council Meeting

Manager Mackenzie said it is hoped the boil water notice will be lifted by mid-day on Thursday.

Executive Session – NONE

The Council meeting adjourned at 7:50 PM on motion of Councilor Hemmerick, seconded by Councilor Boutin. **Motion carried on roll call vote, with all voting in favor.**

An audio recording of the meeting is available in the Clerk's office.

Respectfully submitted,

Carolyn S. Dawes, City Clerk

DRAFT



Permit Administrator
 City of Barre
 6 N. Main Street
 Barre, VT 05641
 Phone: (802) 476-0245
 Fax: (802) 476-0263

Permits to Council
 March 14, 2020 to March 19, 2020

Permit#	Permit Type	Owner	Property Address	Permit Description
B20-000018	Building Permit	Damantha Dickinson & Tavian Plant	7 Thurston Place	Demolition and replace drwall, flooring and trim as needed to remove smoke damage and rebuilding front portch due to fire damage.
B20-000020	Building Permit	Aubuchone Realty	214 N Main Street	Replace deteriorated sections of sheetrock in basement with flood resistant materials.
E20-000030	Electrical Permit	HOLLOW INN INC THE	268 S MAIN ST	Electrical work due to renovations Lic #EM-3670
E20-000031	Electrical Permit	Jason Rowell	168 Washington Street	Replace service, hardwire smokes, code updates Lic #EM-04851
Total:		4		

--	--	--	--	--

AUTHORIZATION TO CONDUCT TAX SALES
AND
TO PURCHASE LANDS AND BUILDING AT TAX SALE

The undersigned members of the City Council of the City of Barre, Vermont and Lucas Herring, the Mayor of Barre, Vermont hereby authorize the Delinquent Tax Collector, to schedule and conduct Tax Sales to collect delinquent taxes and/or water/sewer charges for the 2019-2020 tax year, and all earlier years and all previous tax sales, and to incur fees and expenses for legal assistance (to be charged back to the delinquent taxpayer) as allowed by law in the preparation for and conduct of such Tax Sales as aforementioned, and we hereby ratify all such prior actions, and, further, to authorize the City Manager, to purchase at such Tax Sales as aforementioned, any of the properties where no other bona fide purchasers appear or appeared at Tax Sale and the City is the only bidder present at Tax Sale for any given property.

Dated at Barre, Vermont this _____ day of March, 2020.

BARRE CITY COUNCIL

Lucas Herring

Jake Hemmerick

John Steinman

Michael Boutin

Teddy Waszazak

Ericka Reil

Rich Morey

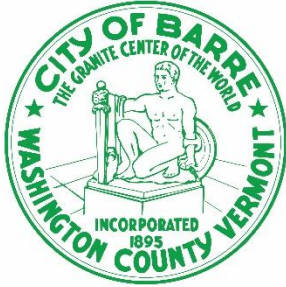

Department of Public Works
6 North Main St Suite 1
Barre, VT 05641

To: Steven Mackenzie P.E. City Manager
From: William Ahearn P.E. Director of Public Works and Engineering
Subject: Purchase approval for Plow truck approved in 2020 \$1.7M Bond
Date: March 20, 2020

I am asking for City Council approval to purchase two plow trucks that were included in the equipment listing in the prior approved bond vote. Overall pricing is very close to the original bond request for both trucks. The trucks are associated with the State purchasing contract pricing so a competitive process has been used. The approved bond amounts were \$175,000 for a full size plow truck and \$63,000 for a small plow truck. Total approved estimated cost was **\$238,000** for both.

A full size plow truck designated International HV507 Viking Package model including plow blade, wing assembly and blade, 7 yd. side-dump dump body, 6 whl w/single axle drive and 38,800 lb GVW and 370 HP, 1200 ft-lbs torque.

\$158,061.00

A mid-size plow truck designated International CV 515 including Fisher 9 foot power angle plow, 5 yd. rear dump body, 6 wheel drive with 19,500 lb GVW and 350HP and 700 ft-lbs. torque.

\$80,053.00

Total expenditure for both trucks is \$238,114

The increase in cost for the smaller truck is directly due to moving from an 11,500 lb GVW up to 19,500 lb GVW – which will easily handle salt loads for the small truck routes.

Prepared For:
CITY OF BARRE
Norewood Southworth
12 North Main Street
Barre, VT 05641-
(802)476 - 3822
Reference ID: N/A

Presented By:
CLARK'S TRUCK CENTER
Russ Clark
6 ORR ROAD
JERICHO VT 05465 -
(802)899-3753



Model Profile
2020 CV515 SFA (CV515)

AXLE CONFIG:	4X4
APPLICATION:	Landscape Dump
MISSION:	Requested GVWR: 23500. Calc. GVWR: 19500 Calc. Start / Grade Ability: 34.08% / 2.15% @ 55 MPH Calc. Geared Speed: 103.5 MPH
DIMENSION:	Wheelbase: 165.00, CA: 83.80, Axle to Frame: 49.00
ENGINE, DIESEL:	{International 6.6} EPA 2017, 350HP @ 2700 RPM, 700 lb-ft Torque @ 1600 RPM, 2900 RPM Governed Speed, 350 Peak HP (Max)
TRANSMISSION, AUTOMATIC:	{Allison 1700 RDS} 5th Generation Controls, Close Ratio, 6-Speed with Double Overdrive, with PTO Provision, Less Retarder, Includes Park Pawl, with 19,500-lb GVW and 26,000-lb GCW Max, On/Off Highway
AXLE, FRONT DRIVING:	{Dana Spicer 60-256} Single Reduction, 7,500-lb Capacity, with Hub Piloted Wheel Mounting
AXLE, REAR, SINGLE:	{Dana Spicer S16-130} Single Reduction, 15,000-lb Capacity, 190 Wheel Ends Gear Ratio: 4.30
CAB:	Conventional, Day Cab
TIRE, FRONT:	(2) 225/70R19.5 Load Range G G647 RSS (GOODYEAR), 640 rev/mile, 87 MPH, All-Position
TIRE, REAR:	(4) 225/70R19.5 Load Range G G622 RSD (GOODYEAR), 641 rev/mile, 87 MPH, Drive
SUSPENSION, REAR, SINGLE:	15,500-lb Capacity, Vari-Rate Springs
PAINT:	Cab schematic 100CX Location 1: 2303, Red (Std) Chassis schematic N/A

Description

Base Chassis, Model CV515 SFA with 165.00 Wheelbase, 83.80 CA, and 49.00 Axle to Frame.

AXLE CONFIGURATION {Navistar} 4x4

FRAME RAILS High Strength Low Alloy Steel (50,000 PSI Yield), Straight Top Flange with Contoured Bottom, Height Transitions from 7.375" (187.325mm) to 9.125" (231.775mm) to 7.625" (193.675mm); Width: 3.079" (78.21mm); Thickness: 0.3125" (7.94mm); 383.3" (9735.8mm) Max OAL

LICENSE PLATE HOLDER Includes Upper & Lower Mounting Plate Hardware, Mounted in Existing Holes in Front Bumper

BUMPER, FRONT Contoured, Steel, Chrome Plated, for CV and RE Bus

WHEELBASE RANGE 128" (325cm) Through and Including 183" (465cm)

AXLE, FRONT DRIVING {Dana Spicer 60-256} Single Reduction, 7,500-lb Capacity, with Hub Piloted Wheel Mounting

AXLE, FRONT DRIVING, LUBE {EmGard FE-75W-90} Synthetic Oil; 1 thru 29.99 Pints

SUSPENSION, FRONT, SPRING Parabolic Taper Leaf, Shackle Type, 7,500-lb Capacity, with Shock Absorbers

BRAKE SYSTEM, HYDRAULIC {Bosch} Split System, with Four Channel ABS, Traction Control, Hydromax Brake Booster and Master Cylinder

DUST SHIELDS, FRONT BRAKE for Hydraulic Brakes

DUST SHIELDS, REAR BRAKE for Hydraulic Brakes

BRAKE, PARKING {Bosch} DSSA Type, 12" x 3"; for Hydraulic Brake Chassis; Foot Operated in Cab; Differential Mounted

BRAKES, FRONT, HYDRAULIC DISC Quadraulic; Four 64mm Diameter Pistons

BRAKES, REAR, HYDRAULIC DISC Quadraulic; Four 64mm Diameter Pistons

STEERING COLUMN Tilting

STEERING WHEEL 4-Spoke; 15" Dia., Black

STEERING GEAR {Bosch S2 8014 Plus} Power

DRIVELINE SYSTEM {Dana Spicer} SPL100 Main Driveline, Direct Mount Transfer Case to Transmission, SPL70 Driveline to Front Axle, for 4x4

EXHAUST SYSTEM Horizontal, Frame Mounted Right Side, Under Rail, for Single Exhaust

ENGINE EXHAUST BRAKE for International 6.6 Engine

MANUAL REGEN Capability

ELECTRICAL SYSTEM 12-Volt for CV Model

ALTERNATOR {Denso SC6} Brush Type, 12 Volt 220 Amp. Capacity

TRAILER BRAKE CONTROL Integrated

BODY BUILDER WIRING Back of Day Cab at Left Frame or Under Crew Cab at Left Frame; Includes One Sealed Connector for Separate Ground/Backup/Left and Right Hand Turn, Left and Right Hand Tail/Stop/Accessory Power and Combined for Left and Right Hand Stop/Turn

BATTERY SYSTEM {VARTA} Maintenance-Free, (2) 12-Volt 1300CCA Total, Top Threaded Stud

RADIO AM/FM/USB Input/Auxiliary Input/SD Card Slot, with 4.2" Color Touch Panel Display

SPEAKERS (6)

BACK-UP ALARM Electric, 102 dBA

TRAILER CONNECTION SOCKET Mounted at Rear of Frame, Wired for Turn Signals Combined with Stop, Compatible with Trailers That Use Combined Stop, Tail, Turn Lamps

Description

STOP, TURN, TAIL & B/U LIGHTS Multi-Function, Sealed, Incandescent Stop, Turn and Tail Lights, Backup Lights with Rear Reflex Reflector, Includes License Plate Light

AUXILIARY HARNESS "Y" Harness for Auxiliary Front Head Lights (High/Low Beam), Marker Lights, and Turn Signals for Front Plow Applications

HORN, ELECTRIC Disc Style

BATTERY BOX Steel, with Plastic Cover, 2 Battery Capacity, Parallel to Rail, 28" Wide, Mounted Left Side Under Cab

HEADLIGHTS Halogen, Composite Aero Design, Chrome Trim Bezel, with Daytime Running Lights

SWITCH, AUXILIARY 1 to 4 Latching Switches with 30-Amp Fuses

CLEARANCE/MARKER LIGHTS (5) Amber LED Lights, Flush Mounted on Cab

STARTING MOTOR 12 Volt

SWITCH, TOGGLE, ROOF WORKLIGHT Lighted; in Overhead Console and Wiring Effects for Customer Furnished Roof Mounted Light

LOGOS EXTERIOR Model Badges

GRILLE Chrome, with Chrome Headlight Bezels

BUG SCREEN Mounted Behind Grille

FRONT END Tilting, Fiberglass, with Three Piece Construction

FENDER EXTENSIONS Molded in Black

PAINT SCHEMATIC, PT-1 Single Color, Design 100

PAINT TYPE Base Coat/Clear Coat, 1-2 Tone

SNOW PLOW PREP PACKAGE Includes Wiring for Roof Mounted Light

GVWR WEIGHT CLASSIFICATION Class 5 (16,001-19,500 lbs)

ENGINE, DIESEL {International 6.6} EPA 2017, 350HP @ 2700 RPM, 700 lb-ft Torque @ 1600 RPM, 2900 RPM Governed Speed, 350 Peak HP (Max)

FAN DRIVE Viscous Screw On Type, Rear Tether, Electronically Controlled

AIR CLEANER Single Element, with Water Separator

FEDERAL EMISSIONS {International 6.6} EPA, OBD and GHG Certified for Calendar Year 2020

THROTTLE, HAND CONTROL Engine Speed Control for PTO; Electronic Controlled, On/Off Switch Mounted on Dash, with Steering Wheel Button Control

GOVERNOR Electronic Road Speed Type; with 75 MPH Default

EMISSION COMPLIANCE Low NOx Idle Engine, Complies with California Clean Air Regulations; Includes "Certified Clean Idle" Decal on Hood

BLOCK HEATER, ENGINE 120V/800W

RADIATOR Aluminum; 3-Row, Down Flow, Front to Back System, 730 SqIn Louvered, with 578 SqIn Charge Air Cooler, with In-Tank Transmission Cooler

TRANSMISSION, AUTOMATIC {Allison 1700 RDS} 5th Generation Controls, Close Ratio, 6-Speed with Double Overdrive, with PTO Provision, Less Retarder, Includes Park Pawl, with 19,500-lb GVW and 26,000-lb GCW Max, On/Off Highway

TRANSFER CASE {Meritor MTC-3203} 2-Speed, Gear Drive, 3,000 lb-ft Torque Rating, Less PTO Provision, Electric Shift Control

SHIFT CONTROL PARAMETERS {Allison} 1000 or 2000 Series Transmissions, Performance Programming

PTO LOCATION Customer Does Not Intend to Install PTO

Description

AXLE, REAR, SINGLE {Dana Spicer S16-130} Single Reduction, 15,000-lb Capacity, 190 Wheel Ends . Gear Ratio: 4.30

SUSPENSION, REAR, SINGLE 15,500-lb Capacity, Vari-Rate Springs

AXLE, REAR, LUBE {EmGard FE-75W-90} Synthetic Oil; 1 thru 29.99 Pints

FUEL TANK Top Draw, Plastic, Rectangular, 17" Tank Depth, 40 US Gal (151L), Includes Auxiliary Draw Port and Fuel Filler Assembly, Mounted Between Frame Rails and Behind Rear Axle

DEF TANK 6.75 US Gal (26L) Capacity, Frame Mounted Outside Right Rail, Under Cab

CAB Conventional, Day Cab

MIRROR, INSIDE REAR VIEW Omit

GLASS, ALL WINDOWS Solar Absorbing, Tint

COLOR, INTERIOR Dark Ash

GAUGE CLUSTER English Speedometer, Includes English Odometer; Includes 3.5" Monochromatic Display with Personalization, Warning Messages and Vehicle Information

SEAT, DRIVER High Back with Integral Headrest, with Recline, Cloth, Manual Adjust Lumbar

SEAT, TWO-MAN PASSENGER High Back with Integral Headrest in Outboard Position, Center Fold-Down Armrest with Storage, Cloth, with Recline

MIRRORS (2) Manual Folding and Extending, Power Adjust, Heated, Turn Signal Indicator Located in Mirror, Black Heads and Arms, for 96" Load Width

CAB INTERIOR TRIM Classic, for Day Cab

WINDOW, POWER (2) in Left and Right Doors

AIR BAG, FRONT, DRIVER SIDE

AIR BAG, FRONT, PASSENGER SIDE

AIR BAG, SIDE, DRIVER Seat Mounted, Outboard Side-Impact Airbag

AIR BAG, SIDE, PASSENGER Seat Mounted, Outboard Side-Impact Airbag

AIR BAG, SIDE CURTAIN Roof Mounted, for Front and Rear Outboard Seating Positions for Driver and Passenger Sides

ACCESS, CAB Bright Aluminum, Driver & Passenger Sides, One Step per Door, for use with Day Cab

AIR CONDITIONER with Heater, Single Zone

WHEELS, FRONT {Accuride 50180} DISC; 19.5x6.75 Rims, Powder Coat Steel, 4-Hand Hole, 8-Stud, 275mm BC, Hub-Piloted, Flanged Nut, with Steel Hubs

WHEELS, REAR {Accuride 50180} DUAL DISC; 19.5x6.75 Rims, Powder Coat Steel, 4-Hand Hole, 8-Stud, 275mm BC, Hub-Piloted, Flanged Nut, with Steel Hubs

(2) TIRE, FRONT 225/70R19.5 Load Range G G647 RSS (GOODYEAR), 640 rev/mile, 87 MPH, All-Position

(4) TIRE, REAR 225/70R19.5 Load Range G G622 RSD (GOODYEAR), 641 rev/mile, 87 MPH, Drive

Cab schematic 100CX

Location 1: 2303, Red (Std)

Chassis schematic N/A

Services Section:

WARRANTY Standard for CV515, Effective with Vehicles Built December 3, 2018 or Later, CTS-3000A

Description

Fisher Minute Mount Plow Hitch

Fisher 9 HC Plow

Engine Mounted Clutch Pump
Frame Mounted Oil Reservoir
One Section Implement Valve
Cable Actuated Implement Control
Dual Dial Hydraulic Spreader Controls
Stainless Hydraulic Lines to the Rear

100U11' Dump Body
Cross Member Supported Floor
Cab Shield
Manual Release Tailgate
DA Under Body Hoist
Pintle Plate w/D-Rings
Front and Rear Mud Flaps w/Front Mounted Anti-Sails
Shot Blasted and Powder Coat Primed
Painted Black

Salt Dogg Single 6 Auger Tailgate Spreader

LED Cab Shield (4) and Corner Post Mounted Strobes
Chassis STT/Back Ups and LED Markers
LED Spot Light
Fisher Plow Lights

Prepared For:
 CITY OF BARRE
 Norewood Southworth
 12 North Main Street
 Barre, VT 05641-
 (802)476 - 3822
 Reference ID: Red

Presented By:
 CLARK'S TRUCK CENTER
 Russ Clark
 6 ORR ROAD
 JERICHO VT 05465 -
 (802)899-3753

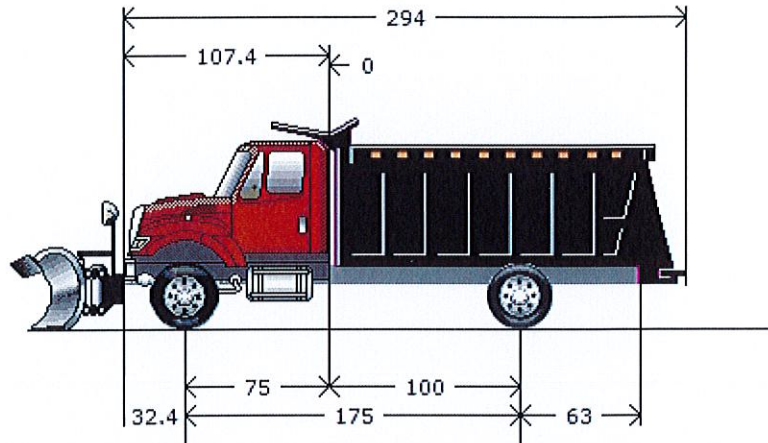

Model Profile
2021 HV507 SFA (HV507)

AXLE CONFIG:	4X2
APPLICATION:	Front Plow and Wing with Spreader
MISSION:	Requested GVWR: 43000. Calc. GVWR: 37780 Calc. Start / Grade Ability: 31.10% / 3.61% @ 55 MPH Calc. Geared Speed: 65.6 MPH
DIMENSION:	Wheelbase: 175.00, CA: 100.00, Axle to Frame: 63.00
ENGINE, DIESEL:	{Cummins L9 370} EPA 2017, 370HP @ 2000 RPM, 1250 lb-ft Torque @ 1400 RPM, 2100 RPM Governed Speed, 370 Peak HP (Max)
TRANSMISSION, AUTOMATIC:	{Allison 3000 RDS} 5th Generation Controls, Close Ratio, 6-Speed with Double Overdrive, with PTO Provision, Less Retarder, Includes Oil Level Sensor, with 80,000-lb GVW and GCW Max, On/Off Highway
CLUTCH:	Omit Item (Clutch & Control)
AXLE, FRONT NON-DRIVING:	{Meritor MFS-20-133A} Wide Track, I-Beam Type, 20,000-lb Capacity
AXLE, REAR, SINGLE:	{Meritor RS-26-185} Single Reduction, 26,000-lb Capacity, Driver Controlled Locking Differential, R Wheel Ends Gear Ratio: 6.14
CAB:	Conventional, Day Cab
TIRE, FRONT:	(2) 12R22.5 Load Range H HSC1 (CONTINENTAL), 482 rev/mile, 75 MPH, All-Position
TIRE, REAR:	(4) 12R22.5 Load Range H G282 MSD (GOODYEAR), 481 rev/mile, 75 MPH, Drive
SUSPENSION, REAR, SINGLE:	{Chalmers 1030 Series} 30,000-lb Capacity, Rubber Springs, 9.37" Ride Height, 7" High Spring X-Low Mount, with 21" Lower Torque Rods, and Shock Absorbers Mounted Forward
FRAME REINFORCEMENT:	Full Outer C-Channel, Heat Treated Alloy Steel (120,000 PSI Yield), 10.813" x 3.892" x 0.312" (274.6mm x 98.8mm x 7.9mm), 480.0" (12192mm) OAL
PAINT:	Cab schematic 100WK Location 1: 2303, Red (Std) Chassis schematic N/A

Description

Base Chassis, Model HV507 SFA with 175.00 Wheelbase, 100.00 CA, and 63.00 Axle to Frame.

AXLE CONFIGURATION {Navistar} 4x2

FRAME RAILS Heat Treated Alloy Steel (120,000 PSI Yield); 10.125" x 3.580" x 0.312" (257.2mm x 90.9mm x 8.0mm); 480.0" (12192) Maximum OAL

FRAME REINFORCEMENT Full Outer C-Channel, Heat Treated Alloy Steel (120,000 PSI Yield), 10.813" x 3.892" x 0.312" (274.6mm x 98.8mm x 7.9mm), 480.0" (12192mm) OAL

BUMPER, FRONT Swept Back, Steel, Heavy Duty

FRAME EXTENSION, FRONT Integral; 20" In Front of Grille, with Outer C-Channel Reinforcement

WHEELBASE RANGE 146" (370cm) Through and Including 195" (495cm)

AXLE, FRONT NON-DRIVING {Meritor MFS-20-133A} Wide Track, I-Beam Type, 20,000-lb Capacity

SPRINGS, FRONT AUXILIARY Rubber

SUSPENSION, FRONT, SPRING Multi-Stage Parabolic Taper Leaf, Shackle Type, 20,000-lb Capacity, with Shock Absorbers

BRAKE SYSTEM, AIR Dual System for Straight Truck Applications

BRAKES, FRONT, AIR CAM 16.5" x 6", Includes 24 SqIn Long Stroke Brake Chambers

TRAILER CONNECTIONS Four-Wheel, with Hand Control Valve and Tractor Protection Valve, for Straight Truck

DRAIN VALVE {Berg} with Pull Chain, for Air Tank

AIR BRAKE ABS {Bendix AntiLock Brake System} 4-Channel (4 Sensor/4 Modulator) Full Vehicle Wheel Control System

AIR DRYER {Wabco System Saver 1200} with Heater

BRAKE CHAMBERS, REAR AXLE {Bendix EverSure} 30/30 Spring Brake

BRAKE CHAMBERS, FRONT AXLE {Bendix} 24 SqIn

BRAKES, REAR, AIR CAM S-Cam; 16.5" x 7.0"; Includes 30/30 Sq.In. Long Stroke Brake Chamber and Spring Actuated Parking Brake

AIR COMPRESSOR {Cummins} 18.7 CFM

AIR DRYER LOCATION Mounted Inside Left Rail, Back of Cab

DUST SHIELDS, FRONT BRAKE for Air Brakes

DUST SHIELDS, REAR BRAKE for Air Brakes

AIR TANK LOCATION (2) : One Mounted Under Each Frame Rail, Front of Rear Suspension, Parallel to Rail

STEERING COLUMN Tilting and Telescoping

STEERING WHEEL 4-Spoke; 18" Dia., Black

STEERING GEAR (2) {Sheppard M100/M80} Dual Power

DRIVELINE SYSTEM {Dana Spicer} SPL170, for 4x2/6x2

AFTERTREATMENT COVER Aluminum

EXHAUST SYSTEM Single, Horizontal Aftertreatment Device, Frame Mounted Right Side Under Cab, for Single Vertical Tail Pipe, Frame Mounted Right Side Back of Cab

ENGINE COMPRESSION BRAKE {Jacobs} for Cummins ISL/L9 Engines; with Selector Switch and On/Off Switch

TAIL PIPE (1) Turnback Type, Bright

EXHAUST HEIGHT 10'

Description

MUFFLER/TAIL PIPE GUARD (1) Aluminum

ELECTRICAL SYSTEM 12-Volt, Standard Equipment

CIGAR LIGHTER Includes Ash Cup

JUMP START STUD (2) Remote Mounted

ALTERNATOR {Leece-Neville AVI160P2013} Brush Type; 12 Volt 160 Amp. Capacity, Pad Mount, with Remote Sense

BODY BUILDER WIRING Back of Day Cab at Left Frame or Under Sleeper, Extended or Crew Cab at Left Frame; Includes Sealed Connectors for Tail/Amber Turn/Marker/ Backup/Accessory Power/Ground and Sealed Connector for Stop/Turn

HORN, AIR (2) Single Tone, Chrome, Roof Mounted, with Lanyard Pull Cord

BATTERY SYSTEM {Deka/EAST PENN 9A31 AGM} Maintenance-Free, (3) AGM 12-Volt 2775CCA Total, Top Threaded Stud

SPEAKERS (2) 6.5" Dual Cone Mounted in Both Doors, (2) 5.25" Dual Cone Mounted in Both B-Pillars

CB RADIO Accommodation Package; Header Mounted; Feeds From Accessory Side of Ignition Switch; Includes Power Source and One (1) Antenna, Antenna Base with Wiring on Left Side Mirror

RADIO AM/FM/WB/Clock/Bluetooth/USB Input/Auxiliary Input

BACK-UP ALARM Electric, 102 dBA

AUXILIARY HARNESS 3.0' for Auxiliary Front Head Lights and Turn Signals for Front Plow Applications

TRAILER CONNECTION SOCKET 7-Way; Mounted at Rear of Frame, Wired for Turn Signals Independent of Stop, Compatible with Trailers That Have Amber or Side Turn Lamps

HORN, ELECTRIC Disc Style

WINDSHIELD WIPER SPD CONTROL Force Wipers to Slowest Intermittent Speed When Park Brake Set and Wipers Left on for a Predetermined Time

CLEARANCE/MARKER LIGHTS (5) {Truck Lite} Amber LED Lights, Flush Mounted on Cab or Sunshade

TEST EXTERIOR LIGHTS Pre-Trip Inspection will Cycle all Exterior Lamps Except Back-up Lights

HEADLIGHTS ON W/WIPERS Headlights Will Automatically Turn on if Windshield Wipers are turned on

STARTING MOTOR {Delco Remy 38MT Type 300} 12 Volt, Less Thermal Over-Crank Protection

INDICATOR, LOW COOLANT LEVEL with Audible Alarm

ALARM, PARKING BRAKE Electric Horn Sounds in Repetitive Manner When Vehicle Park Brake is "NOT" Set, with Ignition "OFF" and any Door Opened

CIRCUIT BREAKERS Manual-Reset (Main Panel) SAE Type III with Trip Indicators, Replaces All Fuses

BATTERY BOX Steel, 2-3 Battery Capacity, Mounted Inside the Cab, Under Passenger Seat

TURN SIGNALS, FRONT Includes LED Side Turn Lights Mounted on Fender

LOGOS EXTERIOR Model Badges

LOGOS EXTERIOR, ENGINE Badges

HOOD, HATCH (01) for Servicing

GRILLE Stationary, Chrome

FRONT END Tilting, Fiberglass, with Three Piece Construction, for WorkStar/HV

PAINT SCHEMATIC, PT-1 Single Color, Design 100

PAINT TYPE Base Coat/Clear Coat, 1-2 Tone

Description

PROMOTIONAL PACKAGE Government Silver Package

CLUTCH Omit Item (Clutch & Control)

ANTI-FREEZE Red, Extended Life Coolant; To -40 Degrees F/ -40 Degrees C, Freeze Protection

BLOCK HEATER, ENGINE 120V/1000W, for Cummins ISB/B6.7/ISL/L9 Engines

PTO EFFECTS, ENGINE FRONT Less PTO Unit, Includes Adapter Plate on Engine Front Mounted

ENGINE, DIESEL {Cummins L9 370} EPA 2017, 370HP @ 2000 RPM, 1250 lb-ft Torque @ 1400 RPM, 2100 RPM Governed Speed, 370 Peak HP (Max)

FAN DRIVE {Horton Drivemaster} Direct Drive Type, Two Speed with Residual Torque Device for Disengaged Fan Speed

RADIATOR Cross Flow, Series System; 1228 SqIn Aluminum Radiator Core with Internal Water to Oil Transmission Cooler and 1167 In Charge Air Cooler

AIR CLEANER Single Element, with Integral Snow Valve and In-Cab Control

FEDERAL EMISSIONS {Cummins L9} EPA, OBD and GHG Certified for Calendar Year 2020

THROTTLE, HAND CONTROL Engine Speed Control; Electronic, Stationary, Variable Speed; Mounted on Steering Wheel

ENGINE CONTROL, REMOTE MOUNTED No Provision Furnished for Remote Mounted Engine Control

EMISSION COMPLIANCE Federal, Does Not Comply with California Clean Air Idle Regulations

TRANSMISSION, AUTOMATIC {Allison 3000 RDS} 5th Generation Controls, Close Ratio, 6-Speed with Double Overdrive, with PTO Provision, Less Retarder, Includes Oil Level Sensor, with 80,000-lb GVW and GCW Max, On/Off Highway

TRANSMISSION SHIFT CONTROL Column Mounted Stalk Shifter

TRANSMISSION OIL Synthetic; 29 thru 42 Pints

ALLISON SPARE INPUT/OUTPUT for Rugged Duty Series (RDS); General Purpose Trucks, Construction

NEUTRAL AT STOP OMIT

SHIFT CONTROL PARAMETERS {Allison} 3000 or 4000 Series Transmissions, Performance Programming

PTO LOCATION Customer Does Not Intend to Install PTO

AXLE, REAR, SINGLE {Meritor RS-26-185} Single Reduction, 26,000-lb Capacity, Driver Controlled Locking Differential, R Wheel Ends . Gear Ratio: 6.14

SUSPENSION, REAR, SINGLE {Chalmers 1030 Series} 30,000-lb Capacity, Rubber Springs, 9.37" Ride Height, 7" High Spring X-Low Mount, with 21" Lower Torque Rods, and Shock Absorbers Mounted Forward

FUEL TANK STRAPS Bright Finish Stainless Steel

DEF TANK 9.5 US Gal (36L) Capacity, Frame Mounted Outside Left Rail, Under Cab

FUEL/WATER SEPARATOR {Racor 400 Series,} with Primer Pump, Includes Water-in-Fuel Sensor

LOCATION FUEL/WATER SEPARATOR Mounted Outside Left Rail, 34" Back of Cab

FUEL TANK Top Draw, Non-Polished Aluminum, 26" Dia, 70 US Gal (265L), Mounted Left Side, Under Cab

CAB Conventional, Day Cab

AIR CONDITIONER with Integral Heater and Defroster

GAUGE CLUSTER Premium Level; English with English Speedometer and Tachometer, for Air Brake Chassis, Includes Engine Coolant Temperature, Primary and Secondary Air Pressure, Fuel and DEF Gauges, Oil Pressure Gauge, Includes 5 Inch LCD Color Display

IP CLUSTER DISPLAY On Board Diagnostics Display of Fault Codes in Gauge Cluster

Description

SEAT, DRIVER {National 2000 195} Air Suspension, High Back with Integral Headrest, Cloth, Isolator, 3 Chamber Lumbar, 2 Position Front Cushion Adjust, -3 to +14 Degree Back Angle Adjust, Cushion and Back Bolsters

GRAB HANDLE, EXTERIOR Chrome, Towel Bar Type, with Anti-Slip Rubber Inserts, for Cab Entry Mounted Left Side at B-Pillar

MIRROR, CONVEX, HOOD MOUNTED {Lang Mekra} (2) Right and Left Sides, Bright, Heated, 7.5" Sq.

SEAT, PASSENGER {Seats, Inc.} Non Suspension, High Back, Fixed Back, Integral Headrest, Cloth, for use with Batteries in Cab

MIRRORS (2) C-Loop, Power Adjust, Heated, LED Clearance Lights, Bright Heads and Arms, 7.5" x 14" Flat Glass, Includes 7.5" x 7" Convex Mirrors, for 102" Load Width

CAB INTERIOR TRIM Diamond, for Day Cab

WINDSHIELD Heated, Single Piece

ARM REST, RIGHT, DRIVER SEAT

WINDOW, POWER (2) and Power Door Locks, Left and Right Doors, Includes Express Down Feature

CAB REAR SUSPENSION Air Bag Type

INSTRUMENT PANEL Wing Panel

ACCESS, CAB Bright Aluminum, Driver & Passenger Sides, Two Steps per Door, for use with Day Cab or Extended Cab

SUNSHADE, EXTERIOR Bright Finish, with Integral Clearance/Marker Lights

WINDSHIELD WASHER RESERVOIR Mounted Under Cab with Remote Fill Mounted Behind Cab Drivers Side

WHEELS, FRONT {Accuride 41730} DISC; 22.5x9.00 Rims, Standard Polish Aluminum, 10-Stud, 285.75mm BC, Hub-Piloted, Flanged Nut, with Steel Hubs

WHEELS, REAR {Accuride 41730} DUAL DISC; 22.5x9.00 Rims, Standard Polish Aluminum, 10-Stud 285.75mm BC, Hub-Piloted, Flanged Nut, with Steel Hubs

BDY INTG, REMOTE POWER MODULE Mounted Inside Cab Behind Driver Seat, Up to 6 Outputs & 6 Inputs, Max 20 amp per Channel, Max 80 amp Total; Includes 1 Switch Pack with Latched Switches

(2) TIRE, FRONT 12R22.5 Load Range H HSC1 (CONTINENTAL), 482 rev/mile, 75 MPH, All-Position

(4) TIRE, REAR 12R22.5 Load Range H G282 MSD (GOODYEAR), 481 rev/mile, 75 MPH, Drive

Cab schematic 100WK

Location 1: 2303, Red (Std)

Chassis schematic N/A

Services Section:

WARRANTY Standard for HV507, HV50B, HV607 Models, Effective with Vehicles Built July 1, 2017 or Later, CTS-2025A

Description

Power Tilt Hitch w/Wing Mount and Twin Chain Tilt
FAH33 Hydraulic Front Mast Assembly Full Trip Hinge 10 Degree w/Lockout
H1059V Hydraulic Shelving Rear Support w/Detachable 3 Point Attach
132WHD RH Wing
HD Full Trip Hydraulic Arms (Cushion Spring Lower)
Sabre Blades
Carbide Moldboard Shoes (Pair)
Front Mounted Large Volume Gear Pump w/Dry Valve
Behind Cab Oil Reservoir w/Low Oil Sensor
Nine Section Load Sharing Implement/Spreader Valve in Behind Cab Enclosure Pedestal Mounted Air Actuated Implement Controls w/
Front Remote Lever EZ Spread 2 Electronic Spreader Control
Stainless Steel Hydraulic Piping to the Front and Rear
PLSD10 Side Dump Body w/Full Remote Lubrication Kit
AR450 Floor/Tipper w/I-Beam Long Member and Cross Member Support Smooth Construction AR450 Driver s Wall and Corten
Structural/Safety Wall Six Panel Air Actuated Tailgate
Cab Shield
DA Telescopic Hoist
Color Camera System w/Dual Feeds
3 Pt Ladder, Gearbox Step, and Inner Body Step
Shovel Holder
Electric Cover w/30 Degree Aluminum Arms, Asphalt Tarp, and Tension Arms Pintle Plate w/D-Rings and Electrical Plug
Front and Rear Mud Flaps w/Front Mounted Anti-Sails
Shot Blasted, Zinc Primed, Epoxy Primed, and High Temperature Baked Painted Dupont Imron Black and High Temperature Baked
LED Cab Shield (4) and LED Heated Corner Post Mounted Strobe System LED Heated Stop/Tail/Turns, LED Heated Back Ups, and LED
Markers
LED Heated Plow Lights
LED Spot Lights (3+2 Rear Heated)
R1142TE Trip Edge Moldboard
PRR Hydraulic Ram Reversing Drive Frame
Standard Push Lug Swivel
Three Chain Level Lift
Carbide and Cover Blades
Moldboard Shoes (Pair)

VT SAFETY INSPECTION, TRIANGLE FLARE KIT, 5# ABC FIRE EXTINGUISHER, MOUNTED ON CAB FLOOR NEXT TO DRIVERS SEAT IN A HEAVY DUTY BRACKET INCLUDING RUBBER HOLD DOWNS. FUEL & DEF



CLARK'S TRUCK CENTER

Established By Elwood Clark in 1927

Clark's Truck Center

6 Orr Rd

Jericho VT 05465

Phone: (802) 899-3753

Purchase Agreement

Contract Date: 03/09/2020

Deal #: DE-01894

Customer #: 27315

Salesperson: Russ Clark

Bill To: **27315**

BARRE,CITY OF

PO BOX 418

BARRE VT 05641-0418

P:(802) 476-0252 | F:(802) 476-0264

Ship To:

BARRE,CITY OF

PO BOX 418

BARRE, VT 05641-0418

Stock#: LH852222	VIN:1HTKTSWK6LH852222	New 2020 INTERNATIONAL CV515	Price:	\$51,131.00
		BODY/PLOW PACKAGE		\$28,850.00
			Total Price	\$79,981.00
			Title Fee	\$35.00
			License Fee	\$12.00
			Temp Tag	\$25.00
			Total	<u>\$80,053.00</u>

THE QUOTATION OF THIS TRUCK/BODY PACKAGE IS PRICED UNDER THE STATE OF VERMONT MUNICIPLE PRICING.

ESTIMATED COMPLETION DATE IS MAY/JUNE TIMEFRAME. CHASSIS IS IN STOCK AT THIS POINT

CHASSIS WOULD BE PAID IN FULL AT TIME OF ARRIVAL AT VIKING BODY COMPANY AND REMAINIG BALANCE DUE AT TIME OF DELIVERY.

This agreement and any documents which are part of this transaction or incorporated herein comprise the entire agreement affecting this Retail Purchase Agreement and no other agreement or understanding of any nature concerning the same has been made or entered into or will be recognized. I have read and accept all of the terms and conditions of this Agreement, and agree to them as if they were printed above my signature. I further acknowledge receipt of a copy of this Agreement. This Agreement shall not become binding until signed and accepted by an Authorized Dealership Representative.

Purchaser's Signature

03/09/2020
Date

Russ Clark
Sales Representative

Co-Purchaser's Signature

03/09/2020
Date

Manager's Signature

03/09/2020
Date

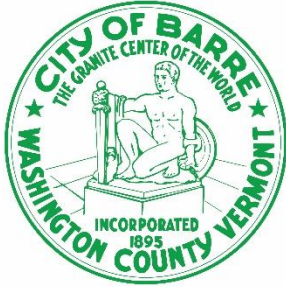

Department of Public Works
6 North Main St Suite 1
Barre, VT 05641

To: Steven Mackenzie P.E. City Manager
From: William Ahearn P.E. Director of Public Works and Engineering
Subject: Purchase approval for Plow truck approved in 2020 \$1.7M Bond
Date: March 20, 2020

I am asking for City Council approval to purchase two plow trucks that were included in the equipment listing in the prior approved bond vote. Overall pricing is very close to the original bond request for both trucks. The trucks are associated with the State purchasing contract pricing so a competitive process has been used. The approved bond amounts were \$175,000 for a full size plow truck and \$63,000 for a small plow truck. Total approved estimated cost was **\$238,000** for both.

A full size plow truck designated International HV507 Viking Package model including plow blade, wing assembly and blade, 7 yd. side-dump dump body, 6 whl w/single axle drive and 38,800 lb GVW and 370 HP, 1200 ft-lbs torque.

\$158,061.00

A mid-size plow truck designated International CV 515 including Fisher 9 foot power angle plow, 5 yd. rear dump body, 6 wheel drive with 19,500 lb GVW and 350HP and 700 ft-lbs. torque.

\$80,053.00

Total expenditure for both trucks is \$238,114

The increase in cost for the smaller truck is directly due to moving from an 11,500 lb GVW up to 19,500 lb GVW – which will easily handle salt loads for the small truck routes.

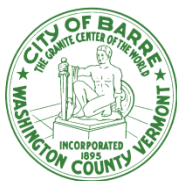

● *City of Barre, Vermont*

“Granite Center of the World”

Steven E. Mackenzie, P.E.
City Manager

6 N. Main St., Suite 2
Barre, VT 05641
Telephone (802) 476-0240
FAX (802) 476-0264
manager@barrecity.org

To: Mayor Lucas Herring and the Barre City Council

From: Steven Mackenzie, P.E., and City Manager

Re: Department Head Reports

Report Date: March 20, 2020

In order to keep you informed of the Department activities of the office, I'm forwarding this report of activities of the City staff for the previous Friday - Thursday. If there are any additional questions please do not hesitate to ask.

1. CLERK/TREASURER'S OFFICE:

- City Hall has been closed to the public. We have made arrangements to accept appointments for researchers to use the vault on a limited basis. Staff is on site to provide service by phone, email and snail mail.
- Annual liquor license renewal applications were mailed out January 14th. All liquor licenses expire on April 30, 2020. Renewals usually include an approved fire department inspection. We may defer such inspections to minimize staff exposure. I spoke with DLC earlier in the week, and they are considering an extension of the deadline.
- Annual unclaimed property reporting is ongoing. The report is due to the VT Treasurer's Unclaimed Property Division by May 1st.
- Voter-approved charter changes have been submitted to the Secretary of State's office, however, the statehouse is now on restricted access, and this will likely affect legislation for the balance of the session. We'll have to wait and see.
- Dog licenses are now available. All dogs are required by state law to be licensed by April 1st, however the Council approved a 30 day extension before charging the late fee. Payments can be accepted through the website, and this system seems to be working well.
- Water & sewer bill payments are due by March 31st. Payments can be accepted through the website. Council has approved waiving late fees and interest on delinquent water & sewer bills through the month of April. Similar arrangements have been made for delinquent taxes.

- All paperwork associated with the March 3rd bond vote has been turned over to our bond attorney, Paul Guiliani. We will be arranging for a bond anticipation note in early April, after the 30 day reconsideration period is over, provided such funding is available.
- The legislature is considering emergency legislation that will change the current Open Meeting Law to allow virtual public meetings without the requirement of a physical location available to the public. There is also emergency legislation being considered to make changes to election law, should the COVID-19 situation continue into the summer election season. There is also consideration being given to extending most state and municipal deadlines until after the state emergency declaration is lifted.

2. BUILDING AND COMMUNITY SERVICES:

- All events at the Civic Center have either been postponed or cancelled.
- We had one entombment this week in the Elmwood vault. Don will be utilized to assist with the cleaning and disinfecting of the Auditorium.
- The Facilities crews have been cleaning and disinfecting Alumni Hall, the AUD, BOR (ice is out!), City Hall and the Public Safety Building. Each building has been “locked down” once the disinfecting has been completed.
- Participated in conference call meetings as we all practice “social distancing”. Stay safe everyone!

2a. RECREATION:

- Department Head will send report with the warrants on Monday.

3. DEPARTMENT OF PERMITTING, PLANNING AND ASSESSING:

Planning – Janet:

- Sunday and Monday finished reviewing and providing comments to the Covid-19 response plan drafted by the Deputy Fire Chief;
- Participating in the Monday, Wednesday and Friday morning Covid-19 staff calls;
- Issued a file review compliance letter to two real estate attorneys;
- Got the Unified Development Ordinance and website updated since I finally received the edits to the zoning map from the December 2019 hearing that made the change to two properties on Ayers Street effective in January 2020;
- Sent to Heather to archive the 2020 complaint forms to date sitting in Jotform to maintain functionality of the website form;
- Added language to the Housing Board of Review webpage regarding the city vote, and that we are waiting on legislative Charter approval, otherwise, the Board and the security deposit rule still apply;

- Uploaded to the City shared drive all plans from the Planning Department for all to have access to;
- Finished creating on the PPA website the remaining Historic District work, and added the stormwater planning work (Central Vermont Plan, Winooski Plan) to the right-side tool bar – check out the interactive story maps! They’re very informative, and COOL;
- Answering questions on the BOR digital sign for emergency use;
- Added to the various website subpages the City Hall closure in effect for COB Thursday 3/19/20 (Planning Commission, Development Review Board, Housing Board, Energy Committee, and PPA webpage), worked with my staff to put information on the website they are comfortable with so that the public can access them appropriately;
- Various phone calls, emails, invoices, internal meetings with fellow staff, City Manager, residents, business owners, etc.

Permitting – Heather:

- Closed 7 electrical permits (electronically adding inspection date, and in paper file);
- Closed 3 building permits (electronically adding inspection date, and in paper file);
- Issued 3 Building Certificates of Occupancy for Code Enforcement and sent to the property owners;
- Issued 2 building permits;
- Issued 3 electrical permits;
- Notified the DRB members there is no April hearing (no development applications);
- Updated the Rental Registry list with new owners, etc. in preparation for the May mailing;
- Working with our Permit software company to tweak the public portal for on line applications to match city payment processing, still ongoing;
- Cleaning office space twice a day;
- Answered phones, emails, waited on customers, filing, and the ever-ongoing updates to both Fire Dept. & Zoning databases for address changes, file uploads, etc.

Assessing Clerk – Kathryn:

- Regular office and assessing work, grand list, 911, property transfer returns, address changes, customers, phone, e-mail requests, assistance and information, filing, computer updates, map copies and lister cards sent to those requesting copies;
- Added to the spreadsheet for the Assessor to use, any permits from the zoning administrator, and any permit closeouts to be listed on the Assessor card system, which is the permit list for the Assessor to complete;
- Received 4 change cards (changes in assessment) from the Assessor that require revisions in the NEMRC system for the 2020 assessment changes in value;
- Continuing working on the 2019 Sales Study with all downloaded from the State with currently all but 10 done. We receive weekly additional transfers for the Study as the State receives the transfers from towns and processes them then adds them to the Sales Study which they download to us for previewing and validation or not;
- Down loaded 128 Homestead filings, 0 E & O, and 0 State Payments into the Grand List doing updates for in NEMRC, files, Grand List and yearly records. The year to date total of Barre City Homesteads filed for 2020 is 773.

3a. CONTRACT ASSESSOR:

- Contractor did not provide report.

4. DEPARTMENT OF PUBLIC WORKS:

- Department Head will send report with the warrants on Monday.

5. FINANCE DIRECTOR:

- Continual COVID-19 discussions and planning – created separate codes for tracking expenses and personnel time
- Completed the necessary financial information for a USDA Grant Application
- Attended bi-weekly meeting with the Manager
- Reviewed AP Invoices

6. DEPARTMENT OF PUBLIC SAFETY:

6a. FIRE DEPARTMENT:

Weekly Fire Activity Report to follow this memo.

6b. POLICE

Police Media Logs to follow this memo.

Check Number	Check Date	Ck Acct	Vendor Number	Vendor Name	Invoice Number	Purchase Order	Check Amount	Invoice Description
136229	03/25/20	01	01012	AETNA	031220		346.51	amb overpayment
					031320		358.77	amb overpayment
Total For Check 136229							705.28	
136230	03/25/20	01	01060	AMAZON CAPITAL SERVICES	1WYNMGFFNYJT		104.69	sign holder
136231	03/25/20	01	01108	ARC MECHANICAL CONTRACTOR	18648		1196.39	labor,switch,trk chg
136232	03/25/20	01	01057	AT&T MOBILITY	030420		109.06	services 2/5-3/4/20
136233	03/25/20	01	23018	AUBUCHON HARDWARE	493056		17.98	tie snap,quick links
					493133B		4.94	adapter
					493142		15.00	propane
					493212		46.78	cylinder,grinder
					493247		10.76	keys
					493264A		4.30	connector,plate
					493267		11.68	mop refills-7020
Total For Check 136233							111.44	
136234	03/25/20	01	02047	BARRE ELECTRIC & LIGHTING	305600		273.04	meter wire
136235	03/25/20	01	02193	BEN'S UNIFORMS	87346		108.00	pants,freight
136236	03/25/20	01	02039	BERGERON JEFFREY	031520		119.00	boots
136237	03/25/20	01	02199	BRENNTAG LUBRICANTS NORTH	6598800		1009.14	grease,serv charge
136238	03/25/20	01	03062	C FORD PROFESSIONAL LETTE	14888		150.61	reflective decals,labor
136239	03/25/20	01	03124	CENTRAL VERMONT MEDICAL C	030120		1339.17	medical supplies
136240	03/25/20	01	04120	DAWES CAROLYN S	031720		62.24	election food
136241	03/25/20	01	04071	DEAD RIVER CO	031020		2431.65	fuel oil,lic fee,fuel tax
					031120		3797.10	fuel oil,lic fee,fuel tax
					67580		1806.18	fuel oil,lic fee,fuel tax
Total For Check 136241							8034.93	
136242	03/25/20	01	04095	DUFRESNE GROUP	14266		95.00	final drawings to Vtrans
136243	03/25/20	01	05059	ENDYNE INC	326090		100.00	lab services
					326341		55.00	lab services
					326510		100.00	lab services
Total For Check 136243							255.00	
136244	03/25/20	01	05030	ESMI OF NEW YORK LLC	21452		2428.85	sludge disposal
136245	03/25/20	01	07073	G D MACHINES	424423		1245.60	labor,materials
136246	03/25/20	01	07006	GREEN MT POWER CORP	049710-0220		304.61	E Cobble Hill Rd water ps
					10586-0220		352.60	Nelson St prv
					149710-0220		23.22	RT 302 prv
					40586-0220		446.78	Main St lights
					634230-0220		20.29	Currier Park panel
					741810-0220		4277.68	164 Reservoir Rd WTP
					934230-0220		227.34	W Cobble Hill ws vault
Total For Check 136246							5652.52	

Check Number	Check Date	Ck Acct	Vendor Number	Vendor Name	Invoice Number	Purchase Order	Check Amount	Invoice Description
136247	03/25/20	01	12054	LAWSON PRODUCTS INC	9307441230		254.08	step reamer set
136248	03/25/20	01	12009	LOWELL MCLEODS INC	S58262		74.73	steel,shackle
136249	03/25/20	01	13189	MILES SUPPLY INC	0135430-02		117.48	masks
					0135585-01		73.80	clear lens glasses
Total For Check 136249							191.28	
136250	03/25/20	01	13133	MOUNTAIN VALLEY SPRINKLER	12368		210.00	labor,service truck
					12369		165.00	labor,service truck
Total For Check 136250							375.00	
136251	03/25/20	01	13134	MOUNTAIN VIEW SECURITY SY	642730		943.75	labor,door
136252	03/25/20	01	14095	NATIONAL GOVERNMENT SERVI	031320		358.77	amb overpayment
136253	03/25/20	01	14016	NELSON ACE HARDWARE	022720		112.26	snowbrush,batteries,hardw
136254	03/25/20	01	14121	NORTHFIELD AUTO SUPPLY	022920		291.79	deicer,rivets,oil
					309150		97.52	battery
					309280		116.00	shocks
					309282		12.99	lacquer thinner
					309490		30.92	radiator hose
					309492		233.64	batteries
					309496		11.11	hose clamps
					309533		18.51	thermostat
Total For Check 136254							812.48	
136256*	03/25/20	01	14164	NOVUS MORRISON SOLAR LLC	172		11989.00	estimated monthly output
136257	03/25/20	01	15020	O'REILLY AUTOMOTIVE INC	022720		76.97	antifreeze,car wash
					186932		9.98	drill bits
Total For Check 136257							86.95	
136258	03/25/20	01	16800	PEOPLE'S UNITED BANK	031120		11318.80	principal,admin fee
136259	03/25/20	01	16003	PIKE INDUSTRIES INC	1069237		1344.39	cold patch
136260	03/25/20	01	17002	QUILL CORP	5478582		262.46	towels,pens,add machine r
136261	03/25/20	01	19002	SAFETY-KLEEN SYSTEMS INC	82435316		264.19	washer solvent
136262	03/25/20	01	19184	SHANGRAW UPHOLSTERY	053		150.00	repair driver's seat
136263	03/25/20	01	19188	SURPASS CHEMICAL CO INC	343900		2454.87	chemicals
136264	03/25/20	01	19160	SWISH WHITE RIVER	W363930		206.35	bonnet-lok II w/riser,frt
					W364796		64.55	towels,freight
Total For Check 136264							270.90	
136265	03/25/20	01	19137	TAFT RIKK	031520		100.00	phone stipend Jan-Feb 20
136266	03/25/20	01	20050	TEXAS REFINERY CORP	193968		348.00	grease
136267	03/25/20	01	20026	TI-SALES INC	0115735		144.00	connector assy,tube
136268	03/25/20	01	20002	TIMES ARGUS ASSOC INC	7521		139.20	advertise agenda 3/17
136269	03/25/20	01	20032	TUCKER MACHINE CO INC	01-15341		59.10	v-belts
136270	03/25/20	01	21002	UNIFIRST CORP	4467048		149.69	uniform rental
					4467049		427.83	uniform rental

Check Number	Check Date	Ck Acct	Vendor Number	Vendor Name	Invoice Number	Purchase Order	Check Amount	Invoice Description
					4467052		105.22	uniform rental
					4467053		71.62	uniform rental
Total For Check 136270							754.36	
136272*	03/25/20	01	22181	VERMONT COMMERCIAL REFRIG	913		575.00	labor,vehicle charge
136273	03/25/20	01	22011	VIKING-CIVES USA	4497447		738.81	bearing,oil reservoir
136274	03/25/20	01	22008	VITALITY ASSOCIATES	031320		870.50	refund parking permits
136275	03/25/20	01	22052	VLCT EMPLOYMENT RESOURCE	30493-02		3883.00	quarterly contribution
136276	03/25/20	01	22102	VT DRINKING WATER WEEK CO	2020-108		100.00	sponsorship
136277	03/25/20	01	23050	W B MASON CO INC	208678699		116.58	wipes-7015
					208719361		22.58	bleach-7015
					208769446		25.85	cleaner-7015
Total For Check 136277							165.01	
136278	03/25/20	01	23041	WORK SAFE	22171		1646.25	posts
					22204		85.00	fasteners
Total For Check 136278							1731.25	
136279	03/25/20	01	01095	A & L MACHINING INC	05381		218.00	labor,steel
136280	03/25/20	01	01088	AFSCME COUNCIL 93	PR-03/25/20	PR01:159	203.00	Payroll Transfer
136281	03/25/20	01	01150	AIRGAS USA LLC	9099102025		50.47	acetylene
					9099102026		127.37	acetylene,adapter
Total For Check 136281							177.84	
136282	03/25/20	01	01057	AT&T MOBILITY	02192020A		136.13	services 1/12-2/11/20
136283	03/25/20	01	01187	ATC GROUP SERVICES LLC	2254918		1154.20	services through 2/28/20
136284	03/25/20	01	03043	CASELLA WASTE MGT INC	2379894		1405.70	trash removal
136285	03/25/20	01	03205	CITY OF BARRE PENSION PLA	PR-03/25/20	PR01:159	536.54	Payroll Transfer
136286	03/25/20	01	03308	COMMUNITY BANK NA	HSA MAR20		3525.00	employer contribution
136287	03/25/20	01	03308	COMMUNITY BANK NA	PR-03/25/20	PR01:159	235.00	Payroll Transfer
136288	03/25/20	01	03337	COMMUNITY BANK NA	PR-03/25/20	PR01:159	34460.01	Payroll Transfer
136289	03/25/20	01	05069	EDWARD JONES	PR-03/25/20	PR01:159	201.00	Payroll Transfer
136290	03/25/20	01	11027	KEY BANK	HSA MAR20		165.88	employer contribution
136291	03/25/20	01	12050	LAKE SUNAPEE BANK	HSA MAR20		650.00	employer contribution
136292	03/25/20	01	13018	MASCOMA SAVINGS BANK	HSA MAR20		450.00	employer contribution
136293	03/25/20	01	13189	MILES SUPPLY INC	0133815-01		497.21	face masks,vapor cartridg
136294	03/25/20	01	13092	MOORE MELAINA J OR CITY O	120500650000		257.00	prop tax overpayment
136295	03/25/20	01	13092	MOORE MELAINA J OR CITY O	12050065000A		475.79	prop tax overpayment
136296	03/25/20	01	14154	NORTH COUNTRY FEDERAL CRE	HSA MAR20		2762.50	employer contribution
136297	03/25/20	01	14154	NORTH COUNTRY FEDERAL CRE	PR-03/25/20	PR01:159	187.00	Payroll Transfer
136298	03/25/20	01	14134	NORTHEAST DELTA DENTAL	040120		6168.88	prem 4/1-4/30/20
136299	03/25/20	01	14089	NORTHFIELD SAVINGS BANK	HSA MAR20		11115.77	employer contribution
136300	03/25/20	01	14089	NORTHFIELD SAVINGS BANK	PR-03/25/20	PR01:159	1715.08	Payroll Transfer
136301	03/25/20	01	15046	OFFICE OF CHILD SUPPORT	PR-03/25/20	PR01:159	98.08	Payroll Transfer
136302	03/25/20	01	15051	ONE CREDIT UNION	HSA MAR20		2895.83	employer contribution
136303	03/25/20	01	15051	ONE CREDIT UNION	PR-03/25/20	PR01:159	2017.13	Payroll Transfer

Starting Date : 03/25/20 Ending Date : 03/25/20

Check Number	Check Date	Ck Acct	Vendor Number	Vendor Name	Invoice Number	Purchase Order	Check Amount	Invoice Description	
136304	03/25/20	01	16600	PASSUMPSIC SAVINGS BANK	HSA MAR20		450.00	employer contribution	
136305	03/25/20	01	16799	PEOPLE'S UNITED BANK	HSA MAR20		1496.58	employer contribution	
136306	03/25/20	01	16799	PEOPLE'S UNITED BANK	PR-03/25/20	PR01:159	80.09	Payroll Transfer	
136307	03/25/20	01	16077	PERSHING LLC	PR-03/25/20	PR01:159	225.00	Payroll Transfer	
136308	03/25/20	01	16102	PRUDENTIAL RETIREMENT	PR-03/25/20	PR01:159	245.00	Payroll Transfer	
136309	03/25/20	01	19160	SWISH WHITE RIVER	W364802		28.38	disinfectant spray,frt	
136310	03/25/20	01	20095	TD BANK	HSA MAR20		3276.07	employer contribution	
136311	03/25/20	01	20095	TD BANK	PR-03/25/20	PR01:159	398.11	Payroll Transfer	
136312	03/25/20	01	20020	TWOMBLY OLIVER L	031820		664.20	tax sale 65 Pleasant St	
136313	03/25/20	01	21005	UNION BANK	HSA MAR20		562.50	employer contribution	
136314	03/25/20	01	21017	UNUM LIFE INS CO OF AMERI	031620		5899.73	prem 4/1-4/30/20	
136315	03/25/20	01	22100	VERMONT DEPT OF TAXES	PR-03/25/20	PR01:159	4354.38	Payroll Transfer	
136316	03/25/20	01	22062	VT STATE EMPLOYEES CREDIT	PR-03/25/20	PR01:159	370.00	Payroll Transfer	

							86 checks for check account 01	153630.71	-----
							Report total for 86 checks	153630.71	=====

Employee Tax Summary Report

by name for check dates 03/25/20 thru 03/25/20

Gross	FWT	FICA	MEDI	SWT	SDI	ERFICA	ERMEDI	FUTA	SUTA	Local	Net
Employee: 0090	ABARE, LANCE R.										
928.80	56.37	55.32	12.94	19.45	0.00	55.32	12.94	0.00	0.00	0.00	690.37
Employee: 0136	AHEARN, WILLIAM E.										
2463.33	169.49	151.49	35.43	134.33	0.00	151.49	35.43	0.00	0.00	0.00	0.00
Employee: 0145	ALDSWORTH, JOSEPH G.										
1542.16	132.93	92.67	21.67	38.06	0.00	92.67	21.67	0.00	0.00	0.00	245.26
Employee: 0417	BARIL, JAMES A.										
2097.24	291.32	122.53	28.66	87.06	0.00	122.53	28.66	0.00	0.00	0.00	0.00
Employee: 0570	BENJAMIN, KENNETH S.										
913.20	90.49	55.75	13.04	27.07	0.00	55.75	13.04	0.00	0.00	0.00	0.00
Employee: 0580	BENSON, NICHOLAS J.										
1323.92	159.31	80.66	18.86	47.72	0.00	80.66	18.86	0.00	0.00	0.00	0.00
Employee: 0590	BERGERON, JEFFREY R.										
1215.80	83.53	70.26	16.43	27.03	0.00	70.26	16.43	0.00	0.00	0.00	841.52
Employee: 1005	BOMBARDIER, TIMOTHY J.										
1730.80	238.30	105.50	24.67	86.42	0.00	105.50	24.67	0.00	0.00	0.00	0.00
Employee: 1050	BOUTIN, MICHAEL A.										
250.00	0.00	15.50	3.63	0.00	0.00	15.50	3.63	0.00	0.00	0.00	230.87
Employee: 1100	BRAMMAN, KATHRYN H.										
1416.01	128.80	87.79	20.54	39.31	0.00	87.79	20.54	0.00	0.00	0.00	1009.76
Employee: 1097	BREAULT, BONNIE J.										
1377.79	178.59	80.67	18.87	53.50	0.00	80.67	18.87	0.00	0.00	0.00	0.00
Employee: 1130	BRENT, DOUGLAS S.										
2384.80	285.89	145.58	34.05	85.77	0.00	145.58	34.05	0.00	0.00	0.00	0.00
Employee: 1390	BULLARD, DON A.										
1793.61	215.99	111.20	26.01	66.80	0.00	111.20	26.01	0.00	0.00	0.00	0.00
Employee: 1397	BULLARD, JONATHAN R.										
2093.73	222.11	125.76	29.42	66.64	0.00	125.76	29.42	0.00	0.00	0.00	1335.81
Employee: 1675	CARMINATI, JOEL F., JR										
748.43	59.25	45.16	10.57	18.00	0.00	45.16	10.57	0.00	0.00	0.00	0.00
Employee: 1720	CETIN, MATTHEW J.										
1564.88	113.56	86.73	20.28	35.45	0.00	86.73	20.28	0.00	0.00	0.00	0.00
Employee: 1810	CHARBONNEAU, MICHAEL J.										
2140.16	284.12	120.94	28.28	85.08	0.00	120.94	28.28	0.00	0.00	0.00	0.00
Employee: 1815	CHASE, SHERRY L.										
710.40	63.31	41.46	9.70	19.17	0.00	41.46	9.70	0.00	0.00	0.00	0.00
Employee: 1964	COPPING, NICHOLAS R.										
2684.23	414.29	158.03	36.96	124.21	0.00	158.03	36.96	0.00	0.00	0.00	1008.71
Employee: 2015	CRUGER, ERIC J.										
1341.47	163.73	82.01	19.18	49.05	0.00	82.01	19.18	0.00	0.00	0.00	0.00
Employee: 2205	CUSHMAN, BRIAN K.										
1564.88	123.87	92.06	21.53	38.33	0.00	92.06	21.53	0.00	0.00	0.00	0.00
Employee: 2240	DAWES, CAROLYN S.										
1162.20	114.58	68.46	16.01	34.24	0.00	68.46	16.01	0.00	0.00	0.00	0.00
Employee: 2330	DEGREENIA, CATHERINE I.										
1521.60	216.25	90.56	21.18	64.20	0.00	90.56	21.18	0.00	0.00	0.00	0.00
Employee: 2332	DEMELL, WILLIAM M.										
1027.32	101.09	59.10	13.82	30.25	0.00	59.10	13.82	0.00	0.00	0.00	0.00
Employee: 2355	DEXTER, DONNEL A.										
1108.41	123.93	62.27	14.56	37.11	0.00	62.27	14.56	0.00	0.00	0.00	65.40
Employee: 2415	DONALD, LANCE B.										
954.60	96.93	57.70	13.49	29.01	0.00	57.70	13.49	0.00	0.00	0.00	684.54

Employee Tax Summary Report

by name for check dates 03/25/20 thru 03/25/20

Gross	FWT	FICA	MEDI	SWT	SDI	ERFICA	ERMEDI	FUTA	SUTA	Local	Net
Employee: 2445	DROWN, JACOB D.										
1227.46	151.36	73.90	17.28	45.34	0.00	73.90	17.28	0.00	0.00	0.00	0.00
Employee: 2570	DUHAIME, ROBERT H.										
1340.50	135.14	76.38	17.86	40.41	0.00	76.38	17.86	0.00	0.00	0.00	0.00
Employee: 2580	DURGIN, STEVEN J.										
1535.54	177.11	87.02	20.35	53.06	0.00	87.02	20.35	0.00	0.00	0.00	0.00
Employee: 2683	EASTMAN, LARRY E., JR										
1466.00	170.34	84.67	19.80	51.03	0.00	84.67	19.80	0.00	0.00	0.00	0.00
Employee: 2980	FARNHAM, BRIAN D.										
2746.49	358.10	168.02	39.30	107.21	0.00	168.02	39.30	0.00	0.00	0.00	0.00
Employee: 3027	FLEURY, JASON R.										
1257.60	129.06	69.18	16.18	38.64	0.00	69.18	16.18	0.00	0.00	0.00	0.00
Employee: 3275	FREY, JACOB D.										
1212.80	85.78	68.77	16.08	25.38	0.00	68.77	16.08	0.00	0.00	0.00	421.28
Employee: 3375	GAYLORD, AMOS R.										
1168.55	126.64	70.46	16.48	37.92	0.00	70.46	16.48	0.00	0.00	0.00	0.00
Employee: 3560	GILBERT, DAVID P.										
950.80	97.50	57.85	13.53	29.18	0.00	57.85	13.53	0.00	0.00	0.00	676.05
Employee: 3690	GRANDFIELD, HEATHER L.										
782.50	66.85	47.39	11.08	33.22	0.00	47.39	11.08	0.00	0.00	0.00	0.00
Employee: 4015	HASTINGS, CLARK H., III										
832.12	73.24	49.73	11.63	21.94	0.00	49.73	11.63	0.00	0.00	0.00	0.00
Employee: 4017	HAYDEN, AMY L.										
1626.91	199.72	93.97	21.98	59.84	0.00	93.97	21.98	0.00	0.00	0.00	0.00
Employee: 4025	HAYNES, WILLIAM D.										
1430.52	156.05	80.42	18.81	46.74	0.00	80.42	18.81	0.00	0.00	0.00	0.00
Employee: 4100	HEDIN, LAURA T.										
1156.00	109.73	68.42	16.00	32.78	0.00	68.42	16.00	0.00	0.00	0.00	0.00
Employee: 04125	HEMMERICK, JACOB M.										
57.69	0.00	3.58	0.84	0.00	0.00	3.58	0.84	0.00	0.00	0.00	0.00
Employee: 4230	HOULE, JONATHAN S.										
2587.61	329.93	159.28	37.26	98.98	0.00	159.28	37.26	0.00	0.00	0.00	0.00
Employee: 4250	HOWARTH, ROBERT C.										
1579.76	75.84	87.85	20.54	24.79	0.00	87.85	20.54	0.00	0.00	0.00	810.24
Employee: 4260	HOYT, EVERETT J.										
1039.58	73.88	59.59	13.94	34.37	0.00	59.59	13.94	0.00	0.00	0.00	0.00
Employee: 4745	KELLY, JOSEPH E., JR										
986.01	32.05	52.57	12.30	12.27	0.00	52.57	12.30	0.00	0.00	0.00	0.00
Employee: 4770	KIRKPATRICK, TROY S.										
1375.20	136.63	79.17	18.52	38.51	0.00	79.17	18.52	0.00	0.00	0.00	0.00
Employee: 4790	KOSAKOWSKI, JOSHUA D.										
1461.60	143.81	88.09	20.61	43.76	0.00	88.09	20.61	0.00	0.00	0.00	0.00
Employee: 4903	LANE, ZEBULYN M.										
1091.20	99.49	67.10	15.69	30.37	0.00	67.10	15.69	0.00	0.00	0.00	0.00
Employee: 4906	LANGEVIN, RAYMOND P.										
1704.60	123.95	105.69	24.72	52.41	0.00	105.69	24.72	0.00	0.00	0.00	0.00
Employee: 4908	LAPERLE, JESSICA L.										
849.05	76.39	50.21	11.74	22.82	0.00	50.21	11.74	0.00	0.00	0.00	0.00
Employee: 4985	LEWIS, BRITTANY L.										
1631.92	170.47	100.68	23.55	51.82	0.00	100.68	23.55	0.00	0.00	0.00	0.00
Employee: 5010	LOWE, ROBERT L.										
1459.12	146.42	82.37	19.26	43.46	0.00	82.37	19.26	0.00	0.00	0.00	0.00

Employee Tax Summary Report

by name for check dates 03/25/20 thru 03/25/20

Gross	FWT	FICA	MEDI	SWT	SDI	ERFICA	ERMEDI	FUTA	SUTA	Local	Net
Employee: 5049	MACHIA, DELPHIA L.										
1594.80	132.83	92.37	21.61	40.08	0.00	92.37	21.61	0.00	0.00	0.00	672.26
Employee: 5048	MACKENZIE, STEVEN E.										
1982.50	207.54	117.56	27.49	84.39	0.00	117.56	27.49	0.00	0.00	0.00	0.00
Employee: 5085	MALONEY, JASON F.										
1216.60	103.84	71.76	16.78	32.74	0.00	71.76	16.78	0.00	0.00	0.00	404.66
Employee: 5290	MARTEL, JOELL J.										
1296.85	137.75	76.03	17.78	41.19	0.00	76.03	17.78	0.00	0.00	0.00	0.00
Employee: 5425	MCGOWAN, JAMES R.										
1902.88	301.41	113.98	26.66	60.85	0.00	113.98	26.66	0.00	0.00	0.00	0.00
Employee: 5269	MCGUIRE, AARON M.										
1092.68	66.09	67.50	15.79	22.52	0.00	67.50	15.79	0.00	0.00	0.00	0.00
Employee: 5270	MCNALLY, DONNA C.										
972.40	105.81	57.17	13.37	31.67	0.00	57.17	13.37	0.00	0.00	0.00	0.00
Employee: 5100	MCTIGUE, PETER J.										
620.52	71.90	38.47	9.00	18.77	0.00	38.47	9.00	0.00	0.00	0.00	482.38
Employee: 5520	METIVIER, CHERYL A.										
1250.65	117.26	77.54	18.14	35.72	0.00	77.54	18.14	0.00	0.00	0.00	0.00
Employee: 5600	MICHELI, STEVEN N.										
1468.80	113.60	87.06	20.36	40.40	0.00	87.06	20.36	0.00	0.00	0.00	1034.07
Employee: 5701	MILLER, ROBERT W.										
2081.18	232.93	123.70	28.93	73.50	0.00	123.70	28.93	0.00	0.00	0.00	1322.02
Employee: 5725	MONAHAN, DAWN M.										
1502.00	126.04	88.00	20.58	38.93	0.00	88.00	20.58	0.00	0.00	0.00	0.00
Employee: 5749	MOREY, RICHARD D.										
250.00	0.00	15.50	3.63	0.00	0.00	15.50	3.63	0.00	0.00	0.00	0.00
Employee: 5765	MORRIS, SCOTT D.										
1716.80	122.82	105.14	24.59	41.78	0.00	105.14	24.59	0.00	0.00	0.00	1211.12
Employee: 5768	MORRISON, CAMDEN A.										
2183.01	250.65	134.37	31.43	75.20	0.00	134.37	31.43	0.00	0.00	0.00	1431.84
Employee: 5770	MOTT, JOHN C.										
124.07	5.10	7.69	1.80	2.14	0.00	7.69	1.80	0.00	0.00	0.00	0.00
Employee: 5880	MURPHY, BRIANNA E.										
1437.20	132.02	88.61	20.73	40.28	0.00	88.61	20.73	0.00	0.00	0.00	0.00
Employee: 5930	NORWAY, JOANNE P.										
718.25	66.21	42.98	10.05	19.98	0.00	42.98	10.05	0.00	0.00	0.00	0.00
Employee: 5940	NYKIEL, BRYAN T.										
944.40	53.78	54.03	12.64	18.73	0.00	54.03	12.64	0.00	0.00	0.00	598.71
Employee: 6030	PARKER, ROWDIE Y.										
1349.60	137.90	82.44	19.28	41.93	0.00	82.44	19.28	0.00	0.00	0.00	0.00
Employee: 6040	PARSHLEY, TONIA C.										
1068.80	88.33	58.92	13.78	26.31	0.00	58.92	13.78	0.00	0.00	0.00	0.00
Employee: 6088	PIERCE, JOEL M.										
1213.20	85.70	70.10	16.39	27.67	0.00	70.10	16.39	0.00	0.00	0.00	0.00
Employee: 6377	POIRIER, HOLDEN R.										
976.80	87.86	58.10	13.59	26.05	0.00	58.10	13.59	0.00	0.00	0.00	0.00
Employee: 6385	PONTBRIAND, JAMES D.										
1225.20	122.60	69.68	16.30	36.71	0.00	69.68	16.30	0.00	0.00	0.00	0.00
Employee: 6395	POULIOT, BROOKE L.										
824.00	58.75	51.09	11.95	20.15	0.00	51.09	11.95	0.00	0.00	0.00	0.00
Employee: 6416	PROTZMAN, TODD A.										
575.00	46.51	35.65	8.34	14.45	0.00	35.65	8.34	0.00	0.00	0.00	0.00

Employee Tax Summary Report

by name for check dates 03/25/20 thru 03/25/20

Gross	FWT	FICA	MEDI	SWT	SDI	ERFICA	ERMEDI	FUTA	SUTA	Local	Net
Employee: 6415	PRUITT, BRITTAIN J.										
1373.84	56.50	76.54	17.90	19.39	0.00	76.54	17.90	0.00	0.00	0.00	0.00
Employee: 6418	PULLMAN, DAVID L.										
650.30	48.98	39.08	9.14	15.14	0.00	39.08	9.14	0.00	0.00	0.00	0.00
Employee: 6440	QUARANTA, STEPHANIE L.										
1243.00	180.36	71.13	16.64	48.54	0.00	71.13	16.64	0.00	0.00	0.00	770.61
Employee: 6600	REALE, MICHAEL R.										
1799.06	178.31	111.54	26.09	53.50	0.00	111.54	26.09	0.00	0.00	0.00	0.00
Employee: 6611	REIL, ERICKA A.										
57.69	0.00	3.58	0.84	0.00	0.00	3.58	0.84	0.00	0.00	0.00	0.00
Employee: 6640	RIVARD, SYLVIE R.										
800.65	77.99	49.33	11.54	23.27	0.00	49.33	11.54	0.00	0.00	0.00	0.00
Employee: 6689	ROCHFORD, ZACHARY J.										
1835.46	138.85	113.80	26.62	46.26	0.00	113.80	26.62	0.00	0.00	0.00	0.00
Employee: 6818	ROULEAU, JOSEPH J.										
1419.56	120.97	82.13	19.21	35.53	0.00	82.13	19.21	0.00	0.00	0.00	1031.70
Employee: 6870	RUBALCABA, DAVID T.										
1628.52	186.03	99.77	23.34	56.70	0.00	99.77	23.34	0.00	0.00	0.00	0.00
Employee: 6874	RYAN, PATTY L.										
384.96	43.63	23.87	5.58	12.88	0.00	23.87	5.58	0.00	0.00	0.00	0.00
Employee: 7049	SCHAUER, RUSSELL A.										
1453.04	84.19	86.22	20.17	27.15	0.00	86.22	20.17	0.00	0.00	0.00	0.00
Employee: 7100	SEAVER, DEBBIE L.										
1353.60	225.33	80.99	18.94	72.03	0.00	80.99	18.94	0.00	0.00	0.00	0.00
Employee: 7190	SHATNEY, JANET E.										
1131.10	74.49	65.32	15.28	24.51	0.00	65.32	15.28	0.00	0.00	0.00	0.00
Employee: 7200	SHAW, BENJAMIN K.										
2209.16	257.16	136.37	31.90	77.15	0.00	136.37	31.90	0.00	0.00	0.00	0.00
Employee: 7220	SHERIDAN, GARY R., JR										
2883.51	246.13	177.14	41.44	74.87	0.00	177.14	41.44	0.00	0.00	0.00	1539.11
Employee: 7312	SMITH, CLINT P.										
1147.16	129.74	69.04	16.15	38.79	0.00	69.04	16.15	0.00	0.00	0.00	720.81
Employee: 7314	SOUTHWORTH, NORWOOD J.										
998.81	110.56	61.68	14.42	33.09	0.00	61.68	14.42	0.00	0.00	0.00	0.00
Employee: 7316	STEINMAN, JOHN F.										
250.00	0.00	15.50	3.63	0.00	0.00	15.50	3.63	0.00	0.00	0.00	0.00
Employee: 7330	STRACHAN, ROBBIE B.										
1861.70	124.38	114.19	26.71	36.22	0.00	114.19	26.71	0.00	0.00	0.00	1440.10
Employee: 7334	STRASSBERGER, KIRK E.										
901.68	57.49	53.55	12.52	19.80	0.00	53.55	12.52	0.00	0.00	0.00	0.00
Employee: 7450	SUPERNAUT, MERTON A.										
915.45	53.60	49.32	11.53	11.78	0.00	49.32	11.53	0.00	0.00	0.00	564.82
Employee: 7465	TAFT, FRANCIS R.										
1286.00	149.18	77.56	18.14	44.68	0.00	77.56	18.14	0.00	0.00	0.00	0.00
Employee: 7520	TILLINGHAST, ZACHARY M.										
1905.67	218.54	113.03	26.43	66.49	0.00	113.03	26.43	0.00	0.00	0.00	0.00
Employee: 7600	TUCKER, RANDALL L.										
1437.70	146.09	82.78	19.36	43.69	0.00	82.78	19.36	0.00	0.00	0.00	878.29
Employee: 7610	TUCKER, RUSSELL W.										
1102.00	116.42	61.18	14.31	34.85	0.00	61.18	14.31	0.00	0.00	0.00	0.00
Employee: 7843	WALLANT, DAVID R.										
2421.60	285.83	150.14	35.11	85.37	0.00	150.14	35.11	0.00	0.00	0.00	0.00

Employee Tax Summary Report

by name for check dates 03/25/20 thru 03/25/20

Gross	FWT	FICA	MEDI	SWT	SDI	ERFICA	ERMEDI	FUTA	SUTA	Local	Net

Employee: 7870	WASZAZAK III, EDWARD C.										
250.00	0.00	15.50	3.63	0.00	0.00	15.50	3.63	0.00	0.00	0.00	0.00
Employee: 8345	WORN, JESSICA L.										
952.45	70.28	56.09	13.12	21.05	0.00	56.09	13.12	0.00	0.00	0.00	0.00
139858.76	13929.77	8319.33	1945.79	4354.38	0.00	8319.33	1945.79	0.00	0.00	0.00	22122.31
=====											

This document has important legal consequences; consultation with an attorney is encouraged with respect to its use or modification. This document should be adapted to the particular circumstances of the contemplated Project and the controlling Laws and Regulations.

**AGREEMENT
BETWEEN OWNER AND ENGINEER
FOR PROFESSIONAL SERVICES**

Prepared by



Issued and Published Jointly by



This Agreement has been prepared for use with EJCDC® C-700, Standard General Conditions of the Construction Contract, 2013 Edition. Their provisions are interrelated, and a change in one may necessitate a change in the other. For guidance on the completion and use of this Agreement, see EJCDC® E-001, Commentary on the EJCDC Engineering Services Agreements, 2013 Edition.

Copyright © 2014:

National Society of Professional Engineers
1420 King Street, Alexandria, VA 22314-2794
(703) 684-2882
www.nspe.org

American Council of Engineering Companies
1015 15th Street N.W., Washington, DC 20005
(202) 347-7474
www.acec.org

American Society of Civil Engineers
1801 Alexander Bell Drive, Reston, VA 20191-4400
(800) 548-2723
www.asce.org

The copyright for this EJCDC document is owned jointly by the three sponsoring organizations listed above. The National Society of Professional Engineers is the Copyright Administrator for the EJCDC documents; please direct all inquiries regarding EJCDC copyrights to NSPE.

NOTE: EJCDC publications may be purchased at www.ejcdc.org, or from any of the sponsoring organizations above.

TABLE OF CONTENTS

	<u>Page</u>
ARTICLE 1 – SERVICES OF ENGINEER	1
1.01 Scope	1
ARTICLE 2 – OWNER’S RESPONSIBILITIES	1
2.01 General	1
ARTICLE 3 – SCHEDULE FOR RENDERING SERVICES	2
3.01 Commencement	2
3.02 Time for Completion	2
ARTICLE 4 – INVOICES AND PAYMENTS	2
4.01 Invoices	2
4.02 Payments	2
ARTICLE 5 – OPINIONS OF COST	3
5.01 Opinions of Probable Construction Cost	3
5.02 Designing to Construction Cost Limit	3
5.03 Opinions of Total Project Costs	3
ARTICLE 6 – GENERAL CONSIDERATIONS	4
6.01 Standards of Performance	4
6.02 Design Without Construction Phase Services	5
6.03 Use of Documents	6
6.04 Electronic Transmittals	6
6.05 Insurance	7
6.06 Suspension and Termination	8
6.07 Controlling Law	9
6.08 Successors, Assigns, and Beneficiaries	9
6.09 Dispute Resolution	10
6.10 Environmental Condition of Site	10
6.11 Indemnification and Mutual Waiver	11
6.12 Records Retention	12
6.13 Miscellaneous Provisions	12
ARTICLE 7 – DEFINITIONS	13
7.01 Defined Terms	13
ARTICLE 8 – EXHIBITS AND SPECIAL PROVISIONS	17
8.01 Exhibits Included:	17
8.02 Total Agreement:	17
8.03 Designated Representatives:	17
8.04 Engineer’s Certifications:	18

**AGREEMENT
BETWEEN OWNER AND ENGINEER
FOR PROFESSIONAL SERVICES**

THIS IS AN AGREEMENT effective as of _____ (“Effective Date”) between

City of Barre, Vermont (Owner) (“Owner”) and

DuBois & King, Inc. (Engineer) (“Engineer”).

Owner's Project, of which Engineer's services under this Agreement are a part, is generally identified as follows:

City of Barre Wastewater Treatment Facility Biosolids Improvements (Project) Part II.

Other terms used in this Agreement are defined in Article 7.

Engineer's services under this Agreement are generally identified as follows:

This project includes the Step II design phase for replacement of an outdated cover on Digester No. 2 and the waste gas flare.

Owner and Engineer further agree as follows:

ARTICLE 1 – SERVICES OF ENGINEER

1.01 Scope

- A. Engineer shall provide, or cause to be provided, the services set forth herein and in Exhibit A.

ARTICLE 2 – OWNER’S RESPONSIBILITIES

2.01 General

- A. Owner shall have the responsibilities set forth herein and in Exhibit B.
- B. Owner shall pay Engineer as set forth in Article 4 and Exhibit C.
- C. Owner shall be responsible for all requirements and instructions that it furnishes to Engineer pursuant to this Agreement, and for the accuracy and completeness of all programs, reports, data, and other information furnished by Owner to Engineer pursuant to this Agreement. Engineer may use and rely upon such requirements, programs, instructions, reports, data, and information in performing or furnishing services under this Agreement, subject to any express limitations or reservations applicable to the furnished items.
- D. Owner shall give prompt written notice to Engineer whenever Owner observes or otherwise becomes aware of:
 - 1. any development that affects the scope or time of performance of Engineer’s services;

2. the presence at the Site of any Constituent of Concern; or
3. any relevant, material defect or nonconformance in: (a) Engineer's services, (b) the Work, (c) the performance of any Constructor, or (d) Owner's performance of its responsibilities under this Agreement.

ARTICLE 3 – SCHEDULE FOR RENDERING SERVICES

3.01 Commencement

- A. Engineer is authorized to begin rendering services as of the Effective Date.

3.02 Time for Completion

- A. Engineer shall complete its obligations within a reasonable time. Specific periods of time for rendering services, or specific dates by which services are to be completed, are provided in Exhibit A, and are hereby agreed to be reasonable.
- B. If, through no fault of Engineer, such periods of time or dates are changed, or the orderly and continuous progress of Engineer's services is impaired, or Engineer's services are delayed or suspended, then the time for completion of Engineer's services, and the rates and amounts of Engineer's compensation, shall be adjusted equitably.
- C. If Owner authorizes changes in the scope, extent, or character of the Project or Engineer's services, then the time for completion of Engineer's services, and the rates and amounts of Engineer's compensation, shall be adjusted equitably.
- D. Owner shall make decisions and carry out its other responsibilities in a timely manner so as not to delay the Engineer's performance of its services.
- E. If Engineer fails, through its own fault, to complete the performance required in this Agreement within the time set forth, as duly adjusted, then Owner shall be entitled, as its sole remedy, to the recovery of direct damages, if any, resulting from such failure.

ARTICLE 4 – INVOICES AND PAYMENTS

4.01 Invoices

- A. *Preparation and Submittal of Invoices:* Engineer shall prepare invoices in accordance with its standard invoicing practices and the terms of Exhibit C. Engineer shall submit its invoices to Owner on a monthly basis. Invoices are due and payable within 30 days of receipt.

4.02 Payments

- A. *Application to Interest and Principal:* Payment will be credited first to any interest owed to Engineer and then to principal.

- B. *Failure to Pay:* If Owner fails to make any payment due Engineer for services and expenses within 30 days after receipt of Engineer's invoice, then:
1. amounts due Engineer will be increased at the rate of 1.0% per month (or the maximum rate of interest permitted by law, if less) from said thirtieth day; and
 2. Engineer may, after giving seven days written notice to Owner, suspend services under this Agreement until Owner has paid in full all amounts due for services, expenses, and other related charges. Owner waives any and all claims against Engineer for any such suspension.
- C. *Disputed Invoices:* If Owner disputes an invoice, either as to amount or entitlement, then Owner shall promptly advise Engineer in writing of the specific basis for doing so, may withhold only that portion so disputed, and must pay the undisputed portion subject to the terms of Paragraph 4.01.
- D. *Sales or Use Taxes:* If after the Effective Date any governmental entity takes a legislative action that imposes additional sales or use taxes on Engineer's services or compensation under this Agreement, then Engineer may invoice such additional sales or use taxes for reimbursement by Owner. Owner shall reimburse Engineer for the cost of such invoiced additional sales or use taxes; such reimbursement shall be in addition to the compensation to which Engineer is entitled under the terms of Exhibit C.

ARTICLE 5 – OPINIONS OF COST

5.01 *Opinions of Probable Construction Cost*

- A. Engineer's opinions (if any) of probable Construction Cost are to be made on the basis of Engineer's experience, qualifications, and general familiarity with the construction industry. However, because Engineer has no control over the cost of labor, materials, equipment, or services furnished by others, or over contractors' methods of determining prices, or over competitive bidding or market conditions, Engineer cannot and does not guarantee that proposals, bids, or actual Construction Cost will not vary from opinions of probable Construction Cost prepared by Engineer. If Owner requires greater assurance as to probable Construction Cost, then Owner agrees to obtain an independent cost estimate.

5.02 *Designing to Construction Cost Limit*

- A. If a Construction Cost limit is established between Owner and Engineer, such Construction Cost limit and a statement of Engineer's rights and responsibilities with respect thereto will be specifically set forth in Exhibit F to this Agreement.

5.03 *Opinions of Total Project Costs*

- A. The services, if any, of Engineer with respect to Total Project Costs shall be limited to assisting the Owner in tabulating the various categories that comprise Total Project Costs. Engineer assumes no responsibility for the accuracy of any opinions of Total Project Costs.

ARTICLE 6 – GENERAL CONSIDERATIONS

6.01 *Standards of Performance*

- A. *Standard of Care:* The standard of care for all professional engineering and related services performed or furnished by Engineer under this Agreement will be the care and skill ordinarily used by members of the subject profession practicing under similar circumstances at the same time and in the same locality. Engineer makes no warranties, express or implied, under this Agreement or otherwise, in connection with any services performed or furnished by Engineer.
- B. *Technical Accuracy:* Owner shall not be responsible for discovering deficiencies in the technical accuracy of Engineer's services. Engineer shall correct deficiencies in technical accuracy without additional compensation, unless such corrective action is directly attributable to deficiencies in Owner-furnished information.
- C. *Consultants:* Engineer may retain such Consultants as Engineer deems necessary to assist in the performance or furnishing of the services, subject to reasonable, timely, and substantive objections by Owner.
- D. *Reliance on Others:* Subject to the standard of care set forth in Paragraph 6.01.A, Engineer and its Consultants may use or rely upon design elements and information ordinarily or customarily furnished by others, including, but not limited to, specialty contractors, manufacturers, suppliers, and the publishers of technical standards.
- E. *Compliance with Laws and Regulations, and Policies and Procedures:*
 - 1. Engineer and Owner shall comply with applicable Laws and Regulations.
 - 2. Engineer shall comply with any and all policies, procedures, and instructions of Owner that are applicable to Engineer's performance of services under this Agreement and that Owner provides to Engineer in writing, subject to the standard of care set forth in Paragraph 6.01.A, and to the extent compliance is not inconsistent with professional practice requirements.
 - 3. This Agreement is based on Laws and Regulations and Owner-provided written policies and procedures as of the Effective Date. The following may be the basis for modifications to Owner's responsibilities or to Engineer's scope of services, times of performance, or compensation:
 - a. changes after the Effective Date to Laws and Regulations;
 - b. the receipt by Engineer after the Effective Date of Owner-provided written policies and procedures;
 - c. changes after the Effective Date to Owner-provided written policies or procedures.
- F. Engineer shall not be required to sign any document, no matter by whom requested, that would result in the Engineer having to certify, guarantee, or warrant the existence of

conditions whose existence the Engineer cannot ascertain. Owner agrees not to make resolution of any dispute with the Engineer or payment of any amount due to the Engineer in any way contingent upon the Engineer signing any such document.

- G. The general conditions for any construction contract documents prepared hereunder are to be EJCDC® C-700 "Standard General Conditions of the Construction Contract" (2013 Edition), prepared by the Engineers Joint Contract Documents Committee, unless expressly indicated otherwise in Exhibit J or elsewhere in this Agreement.
- H. Engineer shall not at any time supervise, direct, control, or have authority over any Constructor's work, nor shall Engineer have authority over or be responsible for the means, methods, techniques, sequences, or procedures of construction selected or used by any Constructor, or the safety precautions and programs incident thereto, for security or safety at the Site, nor for any failure of a Constructor to comply with Laws and Regulations applicable to that Constructor's furnishing and performing of its work. Engineer shall not be responsible for the acts or omissions of any Constructor.
- I. Engineer neither guarantees the performance of any Constructor nor assumes responsibility for any Constructor's, failure to furnish and perform the Work in accordance with the Construction Contract Documents.
- J. Engineer shall not be responsible for any decision made regarding the Construction Contract Documents, or any application, interpretation, clarification, or modification of the Construction Contract Documents, other than those made by Engineer or its Consultants.
- K. Engineer is not required to provide and does not have any responsibility for surety bonding or insurance-related advice, recommendations, counseling, or research, or enforcement of construction insurance or surety bonding requirements.
- L. Engineer's services do not include providing legal advice or representation.
- M. Engineer's services do not include (1) serving as a "municipal advisor" for purposes of the registration requirements of Section 975 of the Dodd-Frank Wall Street Reform and Consumer Protection Act (2010) or the municipal advisor registration rules issued by the Securities and Exchange Commission, or (2) advising Owner, or any municipal entity or other person or entity, regarding municipal financial products or the issuance of municipal securities, including advice with respect to the structure, timing, terms, or other similar matters concerning such products or issuances.
- N. While at the Site, Engineer, its Consultants, and their employees and representatives shall comply with the applicable requirements of Contractor's and Owner's safety programs of which Engineer has been informed in writing.

6.02 *Design Without Construction Phase Services*

- A. Engineer shall be responsible only for those Construction Phase services expressly required of Engineer in Exhibit A, Paragraph A1.05. With the exception of such expressly required services, Engineer shall have no design, Shop Drawing review, or other

obligations during construction, and Owner assumes all responsibility for the application and interpretation of the Construction Contract Documents, review and response to Contractor claims, Construction Contract administration, processing of Change Orders and submittals, revisions to the Construction Contract Documents during construction, construction observation and review, review of Contractor's payment applications, and all other necessary Construction Phase administrative, engineering, and professional services. Owner waives all claims against the Engineer that may be connected in any way to Construction Phase administrative, engineering, or professional services except for those services that are expressly required of Engineer in Exhibit A.

6.03 *Use of Documents*

- A. All Documents are instruments of service, and Engineer shall retain an ownership and property interest therein (including the copyright and the right of reuse at the discretion of the Engineer) whether or not the Project is completed.
- B. If Engineer is required to prepare or furnish Drawings or Specifications under this Agreement, Engineer shall deliver to Owner at least one original printed record version of such Drawings and Specifications, signed and sealed according to applicable Laws and Regulations.
- C. Owner may make and retain copies of Documents for information and reference in connection with the use of the Documents on the Project. Engineer grants Owner a limited license to use the Documents on the Project, extensions of the Project, and for related uses of the Owner, subject to receipt by Engineer of full payment due and owing for all services relating to preparation of the Documents, and subject to the following limitations: (1) Owner acknowledges that such Documents are not intended or represented to be suitable for use on the Project unless completed by Engineer, or for use or reuse by Owner or others on extensions of the Project, on any other project, or for any other use or purpose, without written verification or adaptation by Engineer; (2) any such use or reuse, or any modification of the Documents, without written verification, completion, or adaptation by Engineer, as appropriate for the specific purpose intended, will be at Owner's sole risk and without liability or legal exposure to Engineer or to its officers, directors, members, partners, agents, employees, and Consultants; (3) Owner shall indemnify and hold harmless Engineer and its officers, directors, members, partners, agents, employees, and Consultants from all claims, damages, losses, and expenses, including attorneys' fees, arising out of or resulting from any use, reuse, or modification of the Documents without written verification, completion, or adaptation by Engineer; and (4) such limited license to Owner shall not create any rights in third parties.
- D. If Engineer at Owner's request verifies the suitability of the Documents, completes them, or adapts them for extensions of the Project or for any other purpose, then Owner shall compensate Engineer at rates or in an amount to be agreed upon by Owner and Engineer.

6.04 *Electronic Transmittals*

- A. Owner and Engineer may transmit, and shall accept, Project-related correspondence, Documents, text, data, drawings, information, and graphics, in electronic media or digital

format, either directly, or through access to a secure Project website, in accordance with a mutually agreeable protocol.

- B. If this Agreement does not establish protocols for electronic or digital transmittals, then Owner and Engineer shall jointly develop such protocols.
- C. When transmitting items in electronic media or digital format, the transmitting party makes no representations as to long term compatibility, usability, or readability of the items resulting from the recipient's use of software application packages, operating systems, or computer hardware differing from those used in the drafting or transmittal of the items, or from those established in applicable transmittal protocols.

6.05 *Insurance*

- A. Engineer shall procure and maintain insurance as set forth in Exhibit G. Engineer shall cause Owner to be listed as an additional insured on any applicable general liability insurance policy carried by Engineer.
- B. Owner shall procure and maintain insurance as set forth in Exhibit G. Owner shall cause Engineer and its Consultants to be listed as additional insureds on any general liability policies carried by Owner, which are applicable to the Project.
- C. Owner shall require Contractor to purchase and maintain policies of insurance covering workers' compensation, general liability, motor vehicle damage and injuries, and other insurance necessary to protect Owner's and Engineer's interests in the Project. Owner shall require Contractor to cause Engineer and its Consultants to be listed as additional insureds with respect to such liability insurance purchased and maintained by Contractor for the Project.
- D. Owner and Engineer shall each deliver to the other certificates of insurance evidencing the coverages indicated in Exhibit G. Such certificates shall be furnished prior to commencement of Engineer's services and at renewals thereafter during the life of the Agreement.
- E. All policies of property insurance relating to the Project, including but not limited to any builder's risk policy, shall allow for waiver of subrogation rights and contain provisions to the effect that in the event of payment of any loss or damage the insurers will have no rights of recovery against any insured thereunder or against Engineer or its Consultants. Owner and Engineer waive all rights against each other, Contractor, the Consultants, and the respective officers, directors, members, partners, employees, agents, consultants, and subcontractors of each and any of them, for all losses and damages caused by, arising out of, or resulting from any of the perils or causes of loss covered by any builder's risk policy and any other property insurance relating to the Project. Owner and Engineer shall take appropriate measures in other Project-related contracts to secure waivers of rights consistent with those set forth in this paragraph.
- F. All policies of insurance shall contain a provision or endorsement that the coverage afforded will not be canceled or reduced in limits by endorsement, and that renewal will not be refused, until at least 10 days prior written notice has been given to the primary

insured. Upon receipt of such notice, the receiving party shall promptly forward a copy of the notice to the other party to this Agreement.

- G. At any time, Owner may request that Engineer or its Consultants, at Owner's sole expense, provide additional insurance coverage, increased limits, or revised deductibles that are more protective than those specified in Exhibit G. If so requested by Owner, and if commercially available, Engineer shall obtain and shall require its Consultants to obtain such additional insurance coverage, different limits, or revised deductibles for such periods of time as requested by Owner, and Exhibit G will be supplemented to incorporate these requirements.

6.06 *Suspension and Termination*

A. *Suspension:*

- 1. *By Owner:* Owner may suspend the Project for up to 90 days upon seven days written notice to Engineer.
- 2. *By Engineer:* Engineer may, after giving seven days written notice to Owner, suspend services under this Agreement if Owner has failed to pay Engineer for invoiced services and expenses, as set forth in Paragraph 4.02.B, or in response to the presence of Constituents of Concern at the Site, as set forth in Paragraph 6.10.D.

B. *Termination:* The obligation to provide further services under this Agreement may be terminated:

- 1. For cause,
 - a. by either party upon 30 days written notice in the event of substantial failure by the other party to perform in accordance with the terms hereof through no fault of the terminating party.
 - b. by Engineer:
 - 1) upon seven days written notice if Owner demands that Engineer furnish or perform services contrary to Engineer's responsibilities as a licensed professional; or
 - 2) upon seven days written notice if the Engineer's services for the Project are delayed or suspended for more than 90 days for reasons beyond Engineer's control, or as the result of the presence at the Site of undisclosed Constituents of Concern, as set forth in Paragraph 6.10.D.
 - 3) Engineer shall have no liability to Owner on account of such termination.
 - c. Notwithstanding the foregoing, this Agreement will not terminate under Paragraph 6.06.B.1.a if the party receiving such notice begins, within seven days of receipt of such notice, to correct its substantial failure to perform and proceeds diligently to cure such failure within no more than 30 days of receipt thereof;

provided, however, that if and to the extent such substantial failure cannot be reasonably cured within such 30 day period, and if such party has diligently attempted to cure the same and thereafter continues diligently to cure the same, then the cure period provided for herein shall extend up to, but in no case more than, 60 days after the date of receipt of the notice.

2. For convenience, by Owner effective upon Engineer's receipt of notice from Owner.
- C. *Effective Date of Termination:* The terminating party under Paragraph 6.06.B may set the effective date of termination at a time up to 30 days later than otherwise provided to allow Engineer to demobilize personnel and equipment from the Site, to complete tasks whose value would otherwise be lost, to prepare notes as to the status of completed and uncompleted tasks, and to assemble Project materials in orderly files.
- D. *Payments Upon Termination:*
1. In the event of any termination under Paragraph 6.06, Engineer will be entitled to invoice Owner and to receive full payment for all services performed or furnished in accordance with this Agreement and all Reimbursable Expenses incurred through the effective date of termination. Upon making such payment, Owner shall have the limited right to the use of Documents, at Owner's sole risk, subject to the provisions of Paragraph 6.03.
 2. In the event of termination by Owner for convenience or by Engineer for cause, Engineer shall be entitled, in addition to invoicing for those items identified in Paragraph 6.06.D.1, to invoice Owner and receive payment of a reasonable amount for services and expenses directly attributable to termination, both before and after the effective date of termination, such as reassignment of personnel, costs of terminating contracts with Engineer's Consultants, and other related close-out costs, using methods and rates for Additional Services as set forth in Exhibit C.

6.07 *Controlling Law*

- A. This Agreement is to be governed by the Laws and Regulations of the state in which the Project is located.

6.08 *Successors, Assigns, and Beneficiaries*

- A. Owner and Engineer are hereby bound and the successors, executors, administrators, and legal representatives of Owner and Engineer (and to the extent permitted by Paragraph 6.08.B the assigns of Owner and Engineer) are hereby bound to the other party to this Agreement and to the successors, executors, administrators and legal representatives (and said assigns) of such other party, in respect of all covenants, agreements, and obligations of this Agreement.
- B. Neither Owner nor Engineer may assign, sublet, or transfer any rights under or interest (including, but without limitation, money that is due or may become due) in this Agreement without the written consent of the other party, except to the extent that any assignment, subletting, or transfer is mandated by law. Unless specifically stated to the

contrary in any written consent to an assignment, no assignment will release or discharge the assignor from any duty or responsibility under this Agreement.

- C. Unless expressly provided otherwise in this Agreement:
1. Nothing in this Agreement shall be construed to create, impose, or give rise to any duty owed by Owner or Engineer to any Constructor, other third-party individual or entity, or to any surety for or employee of any of them.
 2. All duties and responsibilities undertaken pursuant to this Agreement will be for the sole and exclusive benefit of Owner and Engineer and not for the benefit of any other party.
 3. Owner agrees that the substance of the provisions of this Paragraph 6.08.C shall appear in the Construction Contract Documents.

6.09 *Dispute Resolution*

- A. Owner and Engineer agree to negotiate all disputes between them in good faith for a period of 30 days from the date of notice prior to invoking the procedures of Exhibit H or other provisions of this Agreement, or exercising their rights at law.
- B. If the parties fail to resolve a dispute through negotiation under Paragraph 6.09.A, then either or both may invoke the procedures of Exhibit H. If Exhibit H is not included, or if no dispute resolution method is specified in Exhibit H, then the parties may exercise their rights at law.

6.10 *Environmental Condition of Site*

- A. Owner represents to Engineer that as of the Effective Date to the best of Owner's knowledge no Constituents of Concern, other than those disclosed in writing to Engineer, exist at or adjacent to the Site.
- B. If Engineer encounters or learns of an undisclosed Constituent of Concern at the Site, then Engineer shall notify (1) Owner and (2) appropriate governmental officials if Engineer reasonably concludes that doing so is required by applicable Laws or Regulations.
- C. It is acknowledged by both parties that Engineer's scope of services does not include any services related to unknown or undisclosed Constituents of Concern. If Engineer or any other party encounters, uncovers, or reveals an undisclosed Constituent of Concern, then Owner shall promptly determine whether to retain a qualified expert to evaluate such condition or take any necessary corrective action.
- D. If investigative or remedial action, or other professional services, are necessary with respect to undisclosed Constituents of Concern, or if investigative or remedial action beyond that reasonably contemplated is needed to address a disclosed or known Constituent of Concern, then Engineer may, at its option and without liability for consequential or any other damages, suspend performance of services on the portion of the Project affected thereby until such portion of the Project is no longer affected.

- E. If the presence at the Site of undisclosed Constituents of Concern adversely affects the performance of Engineer's services under this Agreement, then the Engineer shall have the option of (1) accepting an equitable adjustment in its compensation or in the time of completion, or both; or (2) terminating this Agreement for cause on seven days notice.
- F. Owner acknowledges that Engineer is performing professional services for Owner and that Engineer is not and shall not be required to become an "owner," "arranger," "operator," "generator," or "transporter" of hazardous substances, as defined in the Comprehensive Environmental Response, Compensation, and Liability Act (CERCLA), as amended, which are or may be encountered at or near the Site in connection with Engineer's activities under this Agreement.

6.11 *Indemnification and Mutual Waiver*

- A. *Indemnification by Engineer:* To the fullest extent permitted by Laws and Regulations, Engineer shall indemnify and hold harmless Owner, and Owner's officers, directors, members, partners, agents, consultants, and employees, from losses, damages, and judgments (including reasonable consultants' and attorneys' fees and expenses) arising from third-party claims or actions relating to the Project, provided that any such claim, action, loss, damages, or judgment is attributable to bodily injury, sickness, disease, or death, or to injury to or destruction of tangible property (other than the Work itself), including the loss of use resulting therefrom, but only to the extent caused by any negligent act or omission of Engineer or Engineer's officers, directors, members, partners, agents, employees, or Consultants. **This indemnification provision is subject to and limited by the provisions, if any, agreed to by Owner and Engineer in Exhibit I, "Limitations of Liability."**
- B. *Indemnification by Owner:* Owner shall indemnify and hold harmless Engineer and its officers, directors, members, partners, agents, employees, and Consultants as required by Laws and Regulations and to the extent (if any) required in Exhibit I, "Limitations of Liability."
- C. *Environmental Indemnification:* To the fullest extent permitted by Laws and Regulations, Owner shall indemnify and hold harmless Engineer and its officers, directors, members, partners, agents, employees, and Consultants from all claims, costs, losses, damages, actions, and judgments (including reasonable consultants' and attorneys fees and expenses) caused by, arising out of, relating to, or resulting from a Constituent of Concern at, on, or under the Site, provided that (1) any such claim, cost, loss, damages, action, or judgment is attributable to bodily injury, sickness, disease, or death, or to injury to or destruction of tangible property (other than the Work itself), including the loss of use resulting therefrom, and (2) nothing in this paragraph shall obligate Owner to indemnify any individual or entity from and against the consequences of that individual's or entity's own negligence or willful misconduct.
- D. *No Defense Obligation:* The indemnification commitments in this Agreement do not include a defense obligation by the indemnitor unless such obligation is expressly stated.
- E. *Percentage Share of Negligence:* To the fullest extent permitted by Laws and Regulations, a party's total liability to the other party and anyone claiming by, through, or under the

other party for any cost, loss, or damages caused in part by the negligence of the party and in part by the negligence of the other party or any other negligent entity or individual, shall not exceed the percentage share that the party's negligence bears to the total negligence of Owner, Engineer, and all other negligent entities and individuals.

- F. *Mutual Waiver:* To the fullest extent permitted by Laws and Regulations, Owner and Engineer waive against each other, and the other's employees, officers, directors, members, agents, insurers, partners, and consultants, any and all claims for or entitlement to special, incidental, indirect, or consequential damages arising out of, resulting from, or in any way related to this Agreement or the Project, from any cause or causes.

6.12 *Records Retention*

- A. Engineer shall maintain on file in legible form, for a period of five years following completion or termination of its services, all Documents, records (including cost records), and design calculations related to Engineer's services or pertinent to Engineer's performance under this Agreement. Upon Owner's request, Engineer shall provide a copy of any such item to Owner at cost.

6.13 *Miscellaneous Provisions*

- A. *Notices:* Any notice required under this Agreement will be in writing, addressed to the appropriate party at its address on the signature page and given personally, by registered or certified mail postage prepaid, or by a commercial courier service. All notices shall be effective upon the date of receipt.
- B. *Survival:* All express representations, waivers, indemnifications, and limitations of liability included in this Agreement will survive its completion or termination for any reason.
- C. *Severability:* Any provision or part of the Agreement held to be void or unenforceable under any Laws or Regulations shall be deemed stricken, and all remaining provisions shall continue to be valid and binding upon Owner and Engineer, which agree that the Agreement shall be reformed to replace such stricken provision or part thereof with a valid and enforceable provision that comes as close as possible to expressing the intention of the stricken provision.
- D. *Waiver:* A party's non-enforcement of any provision shall not constitute a waiver of that provision, nor shall it affect the enforceability of that provision or of the remainder of this Agreement.
- E. *Accrual of Claims:* To the fullest extent permitted by Laws and Regulations, all causes of action arising under this Agreement shall be deemed to have accrued, and all statutory periods of limitation shall commence, no later than the date of Substantial Completion.

ARTICLE 7 – DEFINITIONS

7.01 *Defined Terms*

- A. Wherever used in this Agreement (including the Exhibits hereto) terms (including the singular and plural forms) printed with initial capital letters have the meanings indicated in the text above, in the exhibits, or in the following definitions:
1. *Addenda*—Written or graphic instruments issued prior to the opening of bids which clarify, correct, or change the bidding requirements or the proposed Construction Contract Documents.
 2. *Additional Services*—The services to be performed for or furnished to Owner by Engineer in accordance with Part 2 of Exhibit A of this Agreement.
 3. *Agreement*—This written contract for professional services between Owner and Engineer, including all exhibits identified in Paragraph 8.01 and any duly executed amendments.
 4. *Application for Payment*—The form acceptable to Engineer which is to be used by Contractor during the course of the Work in requesting progress or final payments and which is to be accompanied by such supporting documentation as is required by the Construction Contract.
 5. *Basic Services*—The services to be performed for or furnished to Owner by Engineer in accordance with Part 1 of Exhibit A of this Agreement.
 6. *Change Order*—A document which is signed by Contractor and Owner and authorizes an addition, deletion, or revision in the Work or an adjustment in the Construction Contract Price or the Construction Contract Times, or other revision to the Construction Contract, issued on or after the effective date of the Construction Contract.
 7. *Change Proposal*—A written request by Contractor, duly submitted in compliance with the procedural requirements set forth in the Construction Contract, seeking an adjustment in Construction Contract Price or Construction Contract Times, or both; contesting an initial decision by Engineer concerning the requirements of the Construction Contract Documents or the acceptability of Work under the Construction Contract Documents; challenging a set-off against payments due; or seeking other relief with respect to the terms of the Construction Contract.
 8. *Constituent of Concern*—Asbestos, petroleum, radioactive material, polychlorinated biphenyls (PCBs), hazardous waste, and any substance, product, waste, or other material of any nature whatsoever that is or becomes listed, regulated, or addressed pursuant to (a) the Comprehensive Environmental Response, Compensation and Liability Act, 42 U.S.C. §§9601 et seq. (“CERCLA”); (b) the Hazardous Materials Transportation Act, 49 U.S.C. §§5501 et seq.; (c) the Resource Conservation and Recovery Act, 42 U.S.C. §§6901 et seq. (“RCRA”); (d) the Toxic Substances Control Act, 15 U.S.C. §§2601 et seq.; (e) the Clean Water Act, 33 U.S.C. §§1251 et seq.; (f) the Clean Air Act, 42 U.S.C. §§7401 et seq.; or (g) any other federal, State, or local statute, law, rule, regulation, ordinance,

resolution, code, order, or decree regulating, relating to, or imposing liability or standards of conduct concerning, any hazardous, toxic, or dangerous waste, substance, or material.

9. *Construction Contract*—The entire and integrated written contract between the Owner and Contractor concerning the Work.
10. *Construction Contract Documents*—Those items designated as “Contract Documents” in the Construction Contract, and which together comprise the Construction Contract.
11. *Construction Contract Price*—The money that Owner has agreed to pay Contractor for completion of the Work in accordance with the Construction Contract Documents.
12. *Construction Contract Times*—The number of days or the dates by which Contractor shall: (a) achieve milestones, if any, in the Construction Contract; (b) achieve Substantial Completion; and (c) complete the Work.
13. *Construction Cost*—The cost to Owner of the construction of those portions of the entire Project designed or specified by or for Engineer under this Agreement, including construction labor, services, materials, equipment, insurance, and bonding costs, and allowances for contingencies. Construction Cost does not include costs of services of Engineer or other design professionals and consultants; cost of land or rights-of-way, or compensation for damages to property; Owner’s costs for legal, accounting, insurance counseling, or auditing services; interest or financing charges incurred in connection with the Project; or the cost of other services to be provided by others to Owner. Construction Cost is one of the items comprising Total Project Costs.
14. *Constructor*—Any person or entity (not including the Engineer, its employees, agents, representatives, and Consultants), performing or supporting construction activities relating to the Project, including but not limited to Contractors, Subcontractors, Suppliers, Owner’s work forces, utility companies, other contractors, construction managers, testing firms, shippers, and truckers, and the employees, agents, and representatives of any or all of them.
15. *Consultants*—Individuals or entities having a contract with Engineer to furnish services with respect to this Project as Engineer’s independent professional associates and consultants; subcontractors; or vendors.
16. *Contractor*—The entity or individual with which Owner enters into a Construction Contract.
17. *Documents*—Data, reports, Drawings, Specifications, Record Drawings, building information models, civil integrated management models, and other deliverables, whether in printed or electronic format, provided or furnished in appropriate phases by Engineer to Owner pursuant to this Agreement.
18. *Drawings*—That part of the Construction Contract Documents that graphically shows the scope, extent, and character of the Work to be performed by Contractor.

19. *Effective Date*—The date indicated in this Agreement on which it becomes effective, but if no such date is indicated, the date on which this Agreement is signed and delivered by the last of the parties to sign and deliver.
20. *Engineer*—The individual or entity named as such in this Agreement.
21. *Field Order*—A written order issued by Engineer which requires minor changes in the Work but does not change the Construction Contract Price or the Construction Contract Times.
22. *Laws and Regulations; Laws or Regulations*—Any and all applicable laws, statutes, rules, regulations, ordinances, codes, and orders of any and all governmental bodies, agencies, authorities, and courts having jurisdiction.
23. *Owner*—The individual or entity named as such in this Agreement and for which Engineer's services are to be performed. Unless indicated otherwise, this is the same individual or entity that will enter into any Construction Contracts concerning the Project.
24. *Project*—The total undertaking to be accomplished for Owner by engineers, contractors, and others, including planning, study, design, construction, testing, commissioning, and start-up, and of which the services to be performed or furnished by Engineer under this Agreement are a part.
25. *Record Drawings*—Drawings depicting the completed Project, or a specific portion of the completed Project, prepared by Engineer as an Additional Service and based on Contractor's record copy of all Drawings, Specifications, Addenda, Change Orders, Work Change Directives, Field Orders, and written interpretations and clarifications, as delivered to Engineer and annotated by Contractor to show changes made during construction.
26. *Reimbursable Expenses*—The expenses incurred directly by Engineer in connection with the performing or furnishing of Basic Services and Additional Services for the Project.
27. *Resident Project Representative*—The authorized representative of Engineer assigned to assist Engineer at the Site during the Construction Phase. As used herein, the term Resident Project Representative or "RPR" includes any assistants or field staff of Resident Project Representative. The duties and responsibilities of the Resident Project Representative, if any, are as set forth in Exhibit D.
28. *Samples*—Physical examples of materials, equipment, or workmanship that are representative of some portion of the Work and that establish the standards by which such portion of the Work will be judged.
29. *Shop Drawings*—All drawings, diagrams, illustrations, schedules, and other data or information that are specifically prepared or assembled by or for Contractor and submitted by Contractor to illustrate some portion of the Work. Shop Drawings, whether approved or not, are not Drawings and are not Construction Contract Documents.

30. *Site*—Lands or areas to be indicated in the Construction Contract Documents as being furnished by Owner upon which the Work is to be performed, including rights-of-way and easements, and such other lands furnished by Owner which are designated for the use of Contractor.
31. *Specifications*—The part of the Construction Contract Documents that consists of written requirements for materials, equipment, systems, standards, and workmanship as applied to the Work, and certain administrative requirements and procedural matters applicable to the Work.
32. *Subcontractor*—An individual or entity having a direct contract with Contractor or with any other Subcontractor for the performance of a part of the Work.
33. *Substantial Completion*—The time at which the Work (or a specified part thereof) has progressed to the point where, in the opinion of Engineer, the Work (or a specified part thereof) is sufficiently complete, in accordance with the Construction Contract Documents, so that the Work (or a specified part thereof) can be utilized for the purposes for which it is intended. The terms “substantially complete” and “substantially completed” as applied to all or part of the Work refer to Substantial Completion thereof.
34. *Supplier*—A manufacturer, fabricator, supplier, distributor, materialman, or vendor having a direct contract with Contractor or with any Subcontractor to furnish materials or equipment to be incorporated in the Work by Contractor or a Subcontractor.
35. *Total Project Costs*—The total cost of planning, studying, designing, constructing, testing, commissioning, and start-up of the Project, including Construction Cost and all other Project labor, services, materials, equipment, insurance, and bonding costs, allowances for contingencies, and the total costs of services of Engineer or other design professionals and consultants, together with such other Project-related costs that Owner furnishes for inclusion, including but not limited to cost of land, rights-of-way, compensation for damages to properties, Owner’s costs for legal, accounting, insurance counseling, and auditing services, interest and financing charges incurred in connection with the Project, and the cost of other services to be provided by others to Owner.
36. *Work*—The entire construction or the various separately identifiable parts thereof required to be provided under the Construction Contract Documents. Work includes and is the result of performing or providing all labor, services, and documentation necessary to produce such construction; furnishing, installing, and incorporating all materials and equipment into such construction; and may include related services such as testing, start-up, and commissioning, all as required by the Construction Contract Documents.
37. *Work Change Directive*—A written directive to Contractor issued on or after the effective date of the Construction Contract, signed by Owner and recommended by Engineer, ordering an addition, deletion, or revision in the Work.

B. *Day*:

1. The word "day" means a calendar day of 24 hours measured from midnight to the next midnight.

ARTICLE 8 – EXHIBITS AND SPECIAL PROVISIONS

8.01 Exhibits Included:

- A. Exhibit A, Engineer's Services.
- B. Exhibit B, Owner's Responsibilities.
- C. Exhibit C, Payments to Engineer for Services and Reimbursable Expenses.
- D. Exhibit D, Duties, Responsibilities and Limitations of Authority of Resident Project Representative. **ONLY APPLICABLE FOR CONSTRUCTION PHASE**
- E. Exhibit E, Notice of Acceptability of Work. **ONLY APPLICABLE FOR CONSTRUCTION PHASE**
- ~~F. Exhibit F, Construction Cost Limit. **NOT USED**~~
- G. Exhibit G, Insurance.
- H. Exhibit H, Dispute Resolution.
- I. Exhibit I, Limitations of Liability.
- J. Exhibit J, Special Provisions.
- K. Exhibit K, Amendment to Owner-Engineer Agreement.

8.02 Total Agreement

- A. This Agreement, (together with the exhibits included above) constitutes the entire agreement between Owner and Engineer and supersedes all prior written or oral understandings. This Agreement may only be amended, supplemented, modified, or canceled by a written instrument duly executed by both parties. Amendments should be based whenever possible on the format of Exhibit K to this Agreement.

8.03 Designated Representatives

- A. With the execution of this Agreement, Engineer and Owner shall designate specific individuals to act as Engineer's and Owner's representatives with respect to the services to be performed or furnished by Engineer and responsibilities of Owner under this Agreement. Such an individual shall have authority to transmit instructions, receive information, and render decisions relative to this Agreement on behalf of the respective party whom the individual represents.

8.04 *Engineer's Certifications*

- A. Engineer certifies that it has not engaged in corrupt, fraudulent, or coercive practices in competing for or in executing the Agreement. For the purposes of this Paragraph 8.04:
1. "corrupt practice" means the offering, giving, receiving, or soliciting of anything of value likely to influence the action of a public official in the selection process or in the Agreement execution;
 2. "fraudulent practice" means an intentional misrepresentation of facts made (a) to influence the selection process or the execution of the Agreement to the detriment of Owner, or (b) to deprive Owner of the benefits of free and open competition;
 3. "coercive practice" means harming or threatening to harm, directly or indirectly, persons or their property to influence their participation in the selection process or affect the execution of the Agreement.

IN WITNESS WHEREOF, the parties hereto have executed this Agreement, the Effective Date of which is indicated on page 1.

Owner:
City of Barre, Vermont

Engineer:
DuBois & King, Inc. Inc.

By: _____

By: _____

Print name: _____

Print name: _____

Title: _____

Title: _____

Date Signed: _____

Date Signed: _____

Engineer License or Firm's
Certificate No. (if required): 00056

State of: Vermont

Address for Owner's receipt of notices:

Address for Engineer's receipt of notices:

City of Barre
6 North Main Street, Suite 1
Barre, Vermont 05641

DuBois & King, Inc.
28 North Main Street
Randolph, Vermont 05060

Designated Representative (Paragraph 8.03.A):

William E. Ahearn, P.E.

Title: Director of Public Works and Engineering

Phone Number: (802) 476-0250

E-Mail Address: PWdirector@barrecity.org

Designated Representative (Paragraph 8.03.A):

Charles K. Goodling, P.E.

Title: Vice President

Phone Number: (802) 728-3376

E-Mail Address: cgoodling@dubois-king.com

This is **EXHIBIT A**, consisting of 5 pages, referred to in and part of the **Agreement between Owner and Engineer for Professional Services** dated when signed by Owner.

Engineer's Services

Article 1 of the Agreement is supplemented to include the following agreement of the parties.

Engineer shall provide Basic and Additional Services as set forth below.

PART 1 – BASIC SERVICES

A1.01 Study and Report Phase

Background:

The Engineer has previously prepared an engineering planning study [Preliminary Engineering Report (PER) and Environmental Report (ER)] that outlined three improvements to the municipal wastewater treatment facility generally described as:

- 1) Replacement of an outdated sludge boiler**
- 2) Replacement of a Primary Digester No. 2 cover and internal piping**
- 3) Replacement of the waste gas flare**

The Owner passed a bond for \$900,000 to fund these improvements. Given the relative priorities and the trades involved during the construction phase, the Owner intends to advance these improvements as two separate design and construction contracts. The first and highest priority is to replace the sludge boiler. For that project, the design is complete with construction planned in the near term. The second priority is to replace the primary digester cover and waste gas flare. The Step II design phase for replacing the primary digester cover and waste gas flare is included herein. The Step III bid and construction phase will be incorporated by an amendment.

A1.02 Preliminary Design Phase

Preliminary Design Phase Services were previously provided and therefore, are not included in this agreement.

A1.03 Final Design Phase (Step II)

The Engineer initiated the design of the digester cover replacement project in 2015 and plans were advanced to an approximate 50-percent completion point. As presented in the PER and coordinated with the Owner, the cover replacement will be based on a new stainless steel cover, with the contract documents identifying that the Contractor can present alternative materials of construction in a value engineering approach via the substitution clause that is described in the specifications. Such requests for substitution will be evaluated in the subsequent Step III construction phase.

No design work has previously been undertaken for the waste gas flare replacement. To complete these designs and prepare the project for the subsequent bid/construction phase, the engineer will:

A.1.03.a Attend a site visit with operating staff in order to:

- Update and confirm project objectives, current conditions, and limits of new work.
- Review digester piping, identify locations where internal piping replacements will connect to existing piping that will remain in service, verify the location and type of existing digester-related controls and confirm upgrade/replacement requirements.
- Review piping associated with the waste gas flare including location where new/replacement buried piping will connect to existing piping that will remain in service.
- Discuss options for how best to address the accumulation of condensate in the gas line that supplies the flare.

A.1.03.b Contact several digester cover manufacturer representatives and request any updated installation details, specifications and/or updated pricing. Update and complete the design of the digester cover replacement accordingly.

A.1.03.c Review electrical and mechanical codes to confirm that necessary offsets from existing buildings and property lines are maintained when siting the new waste gas flare. It is anticipated the new flare will be in relative close proximity to the existing flare.

A.1.03.d Develop details/notes for demolition of the existing flare, and installation of a new flare, including a new buried gas supply pipe and electrical service from the Digester Building to the new flare location, new controls and appurtenances.

A.1.03.e Coordinate with operating staff to understand what adjustments need to be made to the existing SCADA system and/or control systems that are associated with these improvements. The Engineer has not budgeted for a detailed assessment of these current systems, and will rely on information from the Owner to adequately describe the necessary revisions/adjustments.

A.1.03.f Prepare technical specifications for the improvements to accompany the design plans.

A.1.03.g Prepare "front-end" documents using EJDC documents which include Information for Bidders, Owner/Contractor contract, bid form, and other construction contract administrative requirements.

A.1.03.h Using best available information, prepare an Opinion of Probable Cost for the proposed improvements which will include an appropriate level of contingency to reflect the final design stage of the project.

A.1.03.i Advance the design to the 90 percent stage and submit the plans and specifications to the state and Owner for review.

A.1.03.j Attend a 90% project review meeting with representatives of the WID and the Owner to receive any review comments. The Engineer will address the comments and finalize the contract documents for bidding purposes.

A1.04 *Bidding or Negotiating Phase* (not included in this agreement)

A1.05 *Construction Phase* (not included in this agreement)

A.1.06 *Post-Construction* (not included in this agreement)

PART 2 – ADDITIONAL SERVICES

Additional Services are NOT PROVIDED, but can be incorporated via amendment.

This is **EXHIBIT B**, consisting of 4 pages, referred to in and part of the **Agreement between Owner and Engineer for Professional Services** dated when signed by Owner.

Owner's Responsibilities

Article 2 of the Agreement is supplemented to include the following agreement of the parties.

B2.01 In addition to other responsibilities of Owner as set forth in this Agreement, Owner shall at its expense:

- A. Provide Engineer with all criteria and full information as to Owner's requirements for the Project, including design objectives and constraints, space, capacity and performance requirements, flexibility, and expandability, and any budgetary limitations.
- B. Give instructions to Engineer regarding Owner's procurement of construction services (including instructions regarding advertisements for bids, instructions to bidders, and requests for proposals, as applicable), Owner's construction contract practices and requirements, insurance and bonding requirements, electronic transmittals during construction, and other information necessary for the finalization of Owner's bidding-related documents (or requests for proposals or other construction procurement documents), and Construction Contract Documents. Furnish copies (or give specific directions requesting Engineer to use copies already in Engineer's possession) of all design and construction standards, Owner's standard forms, general conditions (if other than EJCDC® C-700, Standard General Conditions of the Construction Contract, 2013 Edition), supplementary conditions, text, and related documents and content for Engineer to include in the draft bidding-related documents (or requests for proposals or other construction procurement documents), and draft Construction Contract Documents, when applicable. Owner shall have responsibility for the final content of (1) such bidding-related documents (or requests for proposals or other construction procurement documents), and (2) those portions of any Construction Contract other than the design (as set forth in the Drawings, Specifications, or otherwise), and other engineering or technical matters; and Owner shall seek the advice of Owner's legal counsel, risk managers, and insurance advisors with respect to the drafting and content of such documents.
- C. Furnish to Engineer any other available information pertinent to the Project including reports and data relative to previous designs, construction, or investigation at or adjacent to the Site.
- D. Following Engineer's assessment of initially-available Project information and data and upon Engineer's request, obtain, furnish, or otherwise make available (if necessary through title searches, or retention of specialists or consultants) such additional Project-related information and data as is reasonably required to enable Engineer to complete its Basic and Additional Services. Such additional information or data would generally include the following:
 1. Property descriptions.

2. Zoning, deed, and other land use restrictions.
 3. Utility and topographic mapping and surveys.
 4. Property, boundary, easement, right-of-way, and other special surveys or data, including establishing relevant reference points.
 5. Explorations and tests of subsurface conditions at or adjacent to the Site; geotechnical reports and investigations; drawings of physical conditions relating to existing surface or subsurface structures at the Site; hydrographic surveys, laboratory tests and inspections of samples, materials, and equipment; with appropriate professional interpretation of such information or data.
 6. Environmental assessments, audits, investigations, and impact statements, and other relevant environmental, historical, or cultural studies relevant to the Project, the Site, and adjacent areas.
 7. Data or consultations as required for the Project but not otherwise identified in this Agreement.
- E. Arrange for safe access to and make all provisions for Engineer to enter upon public and private property as required for Engineer to perform services under the Agreement.
- F. Recognizing and acknowledging that Engineer's services and expertise do not include the following services, provide, as required for the Project:
1. Accounting, bond and financial advisory (including, if applicable, "municipal advisor" services as described in Section 975 of the Dodd-Frank Wall Street Reform and Consumer Protection Act (2010) and the municipal advisor registration rules issued by the Securities and Exchange Commission), independent cost estimating, and insurance counseling services.
 2. Legal services with regard to issues pertaining to the Project as Owner requires, Contractor raises, or Engineer reasonably requests.
 3. Such auditing services as Owner requires to ascertain how or for what purpose Contractor has used the money paid.
- G. Provide the services of an independent testing laboratory to perform all inspections, tests, and approvals of samples, materials, and equipment required by the Construction Contract Documents (other than those required to be furnished or arranged by Contractor), or to evaluate the performance of materials, equipment, and facilities of Owner, prior to their incorporation into the Work with appropriate professional interpretation thereof. Provide Engineer with the findings and reports generated by testing laboratories, including findings and reports obtained from or through Contractor.

- H. Provide reviews, approvals, and permits from all governmental authorities having jurisdiction to approve all phases of the Project designed or specified by Engineer and such reviews, approvals, and consents from others as may be necessary for completion of each phase of the Project.
- I. Advise Engineer of the identity and scope of services of any independent consultants employed by Owner to perform or furnish services in regard to the Project, including, but not limited to, cost estimating, project peer review, value engineering, and constructibility review.
- J. If Owner designates a construction manager or an individual or entity other than, or in addition to, Engineer to represent Owner at the Site, define and set forth as an attachment to this Exhibit B the duties, responsibilities, and limitations of authority of such other party and the relation thereof to the duties, responsibilities, and authority of Engineer.
- K. If more than one prime contract is to be awarded for the Work designed or specified by Engineer, then designate a person or entity to have authority and responsibility for coordinating the activities among the various prime Contractors, and define and set forth the duties, responsibilities, and limitations of authority of such individual or entity and the relation thereof to the duties, responsibilities, and authority of Engineer as an attachment to this Exhibit B that is to be mutually agreed upon and made a part of this Agreement before such services begin.
- L. Inform Engineer in writing of any specific requirements of safety or security programs that are applicable to Engineer, as a visitor to the Site.
- M. Examine all alternative solutions, studies, reports, sketches, Drawings, Specifications, proposals, and other documents presented by Engineer (including obtaining advice of an attorney, risk manager, insurance counselor, financial/municipal advisor, and other advisors or consultants as Owner deems appropriate with respect to such examination) and render in writing timely decisions pertaining thereto.
- N. Inform Engineer regarding any need for assistance in evaluating the possible use of Project Strategies, Technologies, and Techniques, as defined in Exhibit A.
- O. Advise Engineer as to whether Engineer's assistance is requested in identifying opportunities for enhancing the sustainability of the Project.
- P. Place and pay for advertisement for Bids in appropriate publications.
- Q. Furnish to Engineer data as to Owner's anticipated costs for services to be provided by others (including, but not limited to, accounting, bond and financial, independent cost estimating, insurance counseling, and legal advice) for Owner so that Engineer may assist Owner in collating the various cost categories which comprise Total Project Costs.

- R. Attend and participate in the pre-bid conference, bid opening, pre-construction conferences, construction progress and other job related meetings, and Site visits to determine Substantial Completion and readiness of the completed Work for final payment.
- S. Authorize Engineer to provide Additional Services as set forth in Part 2 of Exhibit A of the Agreement, as required.
- T. Perform or provide the following: none.

4. In addition to the Lump Sum, Engineer is also entitled to reimbursement from Owner for the following Reimbursable Expenses (see Appendix 1 for rates or charges): None at this time.
 5. The portion of the Lump Sum amount billed for Engineer's services will be based upon Engineer's estimate of the percentage of the total services actually completed during the billing period. If any Reimbursable Expenses are expressly allowed, Engineer may also bill for any such Reimbursable Expenses incurred during the billing period.
- B. *Period of Service:* The compensation amount stipulated in Compensation Packet BC-1 is conditioned on a period of service not exceeding 6 months. If such period of service is extended, the compensation amount for Engineer's services shall be appropriately adjusted.

COMPENSATION PACKET BC-2: Basic Services – Standard Hourly Rates

Article 2 of the Agreement is supplemented to include the following agreement of the parties:

ARTICLE 2 – OWNER'S RESPONSIBILITIES

C2.01 *Compensation For Basic Services (other than Resident Project Representative) – Standard Hourly Rates Method of Payment*

- C. Owner shall pay Engineer for Basic Services set forth in Exhibit A, except for services of Engineer's Resident Project Representative, if any, as follows:
1. An amount equal to the cumulative hours charged to the Project by each class of Engineer's personnel times Standard Hourly Rates for each applicable billing class for all services performed on the Project, plus Reimbursable Expenses and Engineer's Consultants' charges, if any.
 2. The Standard Hourly Rates charged by Engineer constitute full and complete compensation for Engineer's services, including labor costs, overhead, and profit; the Standard Hourly Rates do not include Reimbursable Expenses or Engineer's Consultants' charges.
 3. Engineer's Reimbursable Expenses Schedule and Standard Hourly Rates are attached to this Exhibit C as Appendices 1 and 2.
 4. The total compensation for services is listed in Compensation Packet BC-1: Basic Services – Lump Sum Paragraph C2.01.
 5. Engineer may alter the distribution of compensation between individual phases of the work noted herein to be consistent with services actually rendered, but shall not exceed the total estimated compensation amount unless approved in writing by Owner. See also C2.03.C.2 below.

6. The total estimated compensation for Engineer's services included in the breakdown by phases as noted in Paragraph C2.01.A.3 incorporates all labor, overhead, profit, Reimbursable Expenses, and Engineer's Consultants' charges.
7. The amounts billed for Engineer's services under Paragraph C2.01 will be based on the cumulative hours charged to the Project during the billing period by each class of Engineer's employees times Standard Hourly Rates for each applicable billing class, plus Reimbursable Expenses and Engineer's Consultants' charges.
8. The Standard Hourly Rates and Reimbursable Expenses Schedule will be adjusted annually (as of January 1st of each year) to reflect equitable changes in the compensation payable to Engineer.

C2.02 Compensation For Reimbursable Expenses

- D. Owner shall pay Engineer for all Reimbursable Expenses at the rates set forth in Appendix 1 to this Exhibit C.
- E. Reimbursable Expenses include the expenses identified in Appendix 1 and the following: transportation (including mileage), lodging, and subsistence incidental thereto; providing and maintaining field office facilities including furnishings and utilities; toll telephone calls, mobile phone charges, and courier charges; reproduction of reports, Drawings, Specifications, bidding-related or other procurement documents, Construction Contract Documents, and similar Project-related items; and Consultants' charges. In addition, if authorized in advance by Owner, Reimbursable Expenses will also include expenses incurred for the use of highly specialized equipment.
- F. The amounts payable to Engineer for Reimbursable Expenses will be the Project-related internal expenses actually incurred or allocated by Engineer, plus all invoiced external Reimbursable Expenses allocable to the Project, the latter multiplied by a factor of 8 percent.

C2.03 Other Provisions Concerning Payment

- G. Whenever Engineer is entitled to compensation for the charges of Engineer's Consultants, those charges shall be the amounts billed by Engineer's Consultants to Engineer times a factor of 8 percent.
- H. *Factors:* The external Reimbursable Expenses and Engineer's Consultants' factors include Engineer's overhead and profit associated with Engineer's responsibility for the administration of such services and costs.
- I. *Estimated Compensation Amounts:*
 1. Engineer's estimate of the amounts that will become payable for specified services are only estimates for planning purposes, are not binding on the parties, and are not the minimum or maximum amounts payable to Engineer under the Agreement.

2. When estimated compensation amounts have been stated herein and it subsequently becomes apparent to Engineer that the total compensation amount thus estimated will be exceeded, Engineer shall give Owner written notice thereof, allowing Owner to consider its options, including suspension or termination of Engineer's services for Owner's convenience. Upon notice, Owner and Engineer promptly shall review the matter of services remaining to be performed and compensation for such services. Owner shall either exercise its right to suspend or terminate Engineer's services for Owner's convenience, agree to such compensation exceeding said estimated amount, or agree to a reduction in the remaining services to be rendered by Engineer, so that total compensation for such services will not exceed said estimated amount when such services are completed. If Owner decides not to suspend the Engineer's services during the negotiations and Engineer exceeds the estimated amount before Owner and Engineer have agreed to an increase in the compensation due Engineer or a reduction in the remaining services, then Engineer shall be paid for all services rendered hereunder.
- J. To the extent necessary to verify Engineer's charges and upon Owner's timely request, Engineer shall make copies of such records available to Owner at cost.

This is **Appendix 1 to EXHIBIT C**, consisting of 1 pages, referred to in and part of the **Agreement between Owner and Engineer for Professional Services** dated when signed by Owner.

Reimbursable Expenses Schedule

Reimbursable Expenses are subject to review and adjustment per Exhibit C. Rates and charges for Reimbursable Expenses as of the date of the Agreement are in accordance with the Attachment C-3, which is hereby made a part of this Agreement.

This is **Appendix 2 to EXHIBIT C**, consisting of 1 pages, referred to in and part of the **Agreement between Owner and Engineer for Professional Services** dated when signed by Owner.

Standard Hourly Rates Schedule

A. *Standard Hourly Rates:*

1. Standard Hourly Rates are set forth in this Appendix 2 to this Exhibit C and include salaries and wages paid to personnel in each billing class plus the cost of customary and statutory benefits, general and administrative overhead, non-project operating costs, and operating margin or profit.
2. The Standard Hourly Rates apply only as specified in Article C2.

B. *Schedule:*

Hourly rates for services performed on or after the date of the Agreement are in accordance with the Attachment C-3, which is hereby made a part of this Agreement.

ATTACHMENT C-1
RUS CERTIFICATION PAGE (MODIFIED from RUS BULLETIN 1780-26, EXHIBIT C)
DEC CERTIFICATION PAGE

PROJECT NAME: City of Barre, Wastewater Treatment Facility, Biosolids Improvements Project
 PROJECT LOCATION: City of Barre, VT
 APPLICANT & LOAN/GRANT NUMBER: _____

The Engineer and Owner hereby concur in the Funding Agency required revision to E-500 (2014). In addition, the Engineer certifies to the following:

All modifications required by DEC and RUS Bulletin 1780-26 have been made in accordance with the terms of the license agreement, which states in part that the Engineer "must plainly show all changes to the Standard EJDC Text, using 'Track Changes' (redline/strikeout), highlighting, or other means of clearly indicating additions and deletions." Such other means may include attachments indicating changes (e.g. Supplementary Conditions modifying the General Conditions).

SUMMARY OF ENGINEERING FEES

Note that the fees indicated on this table are only a summary and if there is a conflict with any provision of Exhibit C, the provisions there overrule the values listed on this table. Fees shown will not be exceeded without the concurrence of the Agency.

Description of Steps and Services	Fee Amount	Basis of Payment (Lump Sum or NTE)
1. Step 0 – Feasibility Study	<u>Services not provided herein</u>	LS/NTE
2. Step I – Preliminary Engineering		
a. Preliminary Engineering Report Services	<u>\$17,242 (Previously completed)</u>	LS/NTE
b. Environmental Information Document Services	<u>Previously completed</u>	LS/NTE
c. Additional Services included in Step I (include additional lines and itemize each item separately)		LS/NTE
3. Step II – Final Design		
a. Basis of Final Design and Final Design Plans and Contract Documents	<u>\$ 9,176 (Sludge Boiler)</u> <u>\$22,900 (Digester Cover & Flare)</u>	LS/NTE
b. Additional Services included in Step II (include additional lines)		LS/NTE
4. Step III		
a. Bid Phase Services	<u>\$ 4,958 (Sludge Boiler)</u>	LS
b. Construction Phase Services (<u>Administration</u>)	<u>\$12,796 (Sludge Boiler)</u>	LS
c. Resident Project Representative Services	<u>\$ 3,353 (Sludge Boiler)</u>	NTE
d. Post Construction Phase Services	<u>\$ 3,558 (Sludge Boiler)</u>	LS
e. Additional Services included in Step III (include additional lines)		LS/NTE
5. Total Engineering Costs	<u>\$73,983 (Total)</u>	
6. Construction Costs		
a. Contract 1 (<u>Sludge Boiler</u>)	<u>\$173,373 (2-19-2020 bid price)</u>	
b. Contract 2 (<u>Digester Cover & Flare</u>)	<u>TBD</u>	
c. Small Purchase		
d. Additional Items (include additional lines)		

- 7. Total Project Cost
- 8. Total Bond Amount

TBD
\$900,000

SCOPE OF SERVICES

The scope of services can be found in the following pages of the contract: Exhibit A

PROGRESS MEETING AND DELIVERABLES

DEC places funding holds on projects at the 30%, 60%, and 90% of engineering Step I & II (planning and final design) services pending a project meeting and deliverables. Holds may be negotiated to add or delete holds based on the needs of the project. This contract involves the following Step 1 deliverables and meetings:

Percent Complete	Approximate Meeting Schedule	Deliverables
30%	<u>N/A (no meeting)</u>	
60%	<u>N/A (no meeting)</u>	
90%	<u>March 2020</u>	<u>Contract Documents (Plans & Specs)</u>
Final	<u>N/A (no meeting) - April 2020</u>	

Any adjustments to engineering fees or changes to maximum estimated values must be approved by the Agency and must include a table of what specific category or categories of fees are being changed, what fees were before and are after the change, and the resulting total fee.

CONSULTING FIRM NAME

DuBois & King, Inc. 2/28/2020

Engineer Date

Charles K. Goodling, P.E., Project Manager

Name and Title

Town of City of Barre, Vermont 2/28/2020

Owner Date

William E. Ahearn, P.E., Director of Public Works and Engineering

Name and Title

Agency Concurrence:

As lender or insurer of funds to defray the costs of this Contract, and without liability for any payments thereunder, the Agency hereby concurs in the form, content, and execution of this Agreement.

Agency Representative Date

Name and Title

Last Revised: 3/26/19



**City of Barre, VT
Biosolids Improvement Project - Part B
Digester Cover and Waste Gas Flare Replacement**

**Final Design Phase (Step II)
224216**

Project Phases & Tasks	Labor Categories						Total Hours
	Project Director	Project Manager/Senior Engineer	Project Engineer	Mechanical Engineer	Electrical Engineer	CADD Technician	
A1.03 FINAL DESIGN PHASE							
a. Site Visit		4	6				10
b. Complete Digester Cover Replacement Design		4	24		4	40	72
c. Review Elect/Mech Codes Specific to Flare Placement			2		2		4
d. Design for Flare Replacement		2	16		12	24	54
e. Identify SCADA/Controls Adjustments		2	2		4		8
f. Technical Specifications			12		8		24
g. Front End Documents		8	2		2	4	14
h. Opinion of Probable Cost		2	8		2		18
i. 90% Submittal			2			2	4
j. Attend 90% Design Review Meeting and Address Comments		4	8		4	8	24
QA/QC Review		8					8
Total Hours:	0	34	82	0	36	78	240



**City of Barre, VT
Biosolids Improvement Project - Part B
Digester Cover and Waste Gas Flare Replacement**

**Final Design Phase (Step II)
224216**

Project Phases & Tasks	Labor Categories						Total Hours
	Project Director	Project Manager/Senior Engineer	Project Engineer	Mechanical Engineer	Electrical Engineer	CADD Technician	
Direct Labor	0	34	82	0	36	78	240
Total Hours:	\$0.00	\$140,000	\$90,000	\$0.00	\$120,000	\$72,000	\$62,000
Hourly Rates:	\$0	\$4,760	\$7,380	\$0	\$4,320	\$5,616	\$620
Labor Cost:							\$22,696

Direct Expenses

I. Subsistence	Transportation:	Vehicles	300	Miles @	\$0.580	/ Mile =	\$174
	Meals:	Partial Per Diem	0	Travel-Air / Ground / Parking Allowance =			\$0
	Rooms & Lodging:	Full Per Diem	0	Days @	\$7.50	/ Day =	\$0
		Hotel	0	Days @	\$25.00	/ Day =	\$0
				Days @	\$70.00	/ Day =	\$0
							Subsistence Total = \$174

II. Support Expenses

	Telephone/Fax =	\$10
	Postage =	\$0
	Reproduction =	\$10
	Copying =	\$10
	Support Total =	\$30

III. Subcontractors

	Topo Survey & Resurvey	\$0
	Hydrogeology Study	\$0
	Subcontractor Total =	\$0

IV. Miscellaneous Expenses

	Computer Charges =	\$0
	Plotting Charges =	\$0
	Special Equipment =	\$0
	Miscellaneous =	\$0
	Miscellaneous Total =	\$0
	Total Direct Expenses =	\$204
	Administrative Fee =	\$0
	Total Cost =	\$204

Cost Summary

Total Labor Cost	\$22,696
Direct Expenses	\$204
Total Price	\$22,900

SCHEDULE OF FEES AND CONTRACT CONDITIONS

	<u>Hourly Rate</u>
Senior Principals	\$175.00
Principals/Directors II	\$160.00
Principals/Directors I	\$150.00
Senior Project Managers	\$140.00
Project Managers.....	\$125.00
Project Managers/Senior Engineers	\$115.00
Environmental Scientists/Field Naturalist	\$ 98.00
Project Engineers II.....	\$ 95.00
Project Engineers I	\$ 90.00
Construction Inspector.....	\$ 95.00
Landscape Architects/Designers.....	\$ 95.00
Staff Engineer/Senior Designers	\$ 80.00
Designers/Technicians II.....	\$ 72.00
Designers/Technicians I	\$ 68.00
Registered Land Surveyors	\$ 98.00
Two-Person Survey Crew	\$120.00
Two-Person Survey Crew with Licensed Surveyor	\$130.00
Three-Person Survey Crew	\$150.00
Three-Person Survey Crew with Licensed Surveyor	\$170.00
Administrative Support.....	\$ 62.00

Notes:

1. Expert Witness Assistance will be quoted separately.
2. DuBois & King, Inc., reserves the right to periodically modify the hourly billing rates detailed above at the sole discretion of DuBois & King, Inc., with or without notice. Invoiced amounts will be based on the Schedule of Fees in effect at the time of invoicing.
3. Overtime labor provided by non-exempt personnel will be invoiced at one and one-half (1 & 1/2) times the appropriate hourly rate as detailed above.

REIMBURSABLE EXPENSES and OTHER DIRECT COSTS including, but not limited to, the following items will be invoiced at cost plus Administrative Fee of 8%:

1. Transportation and subsistence expenses incurred.
2. Shipping charges and insurance for hardware, samples, field test equipment, etc.
3. Long distance telephone calls, telegrams and cables.
4. Transportation to and from jobs.
 - a. Internal Revenue Service standard mileage reimbursement rate for business travel.
 - b. The use of rental cars, trucks, boats, airplanes or other means of transportation at our cost.
5. Reproduction of drawings, reports, and documents and photographs for project records.
6. Direct materials.

This is **EXHIBIT D**, consisting of 5 pages, referred to in and part of the **Agreement between Owner and Engineer for Professional Services** dated when signed by Owner.

ONLY APPLICABLE FOR CONSTRUCTION PHASE

Duties, Responsibilities, and Limitations of Authority of Resident Project Representative

Article 1 of the Agreement is supplemented to include the following agreement of the parties:

ARTICLE 1 - SERVICES OF ENGINEER

D1.01 Resident Project Representative

- A. Engineer shall furnish a Resident Project Representative ("RPR") to assist Engineer in observing progress and quality of the Work. The RPR may provide full time representation or may provide representation to a lesser degree. RPR is Engineer's representative at the Site, will act as directed by and under the supervision of Engineer, and will confer with Engineer regarding RPR's actions.
- B. Through RPR's observations of the Work, including field checks of materials and installed equipment, Engineer shall endeavor to provide further protection for Owner against defects and deficiencies in the Work. However, Engineer shall not, as a result of such RPR observations of the Work, supervise, direct, or have control over the Work, nor shall Engineer (including the RPR) have authority over or responsibility for the means, methods, techniques, sequences, or procedures of construction selected or used by any Constructor, for security or safety at the Site, for safety precautions and programs incident to the Work or any Constructor's work in progress, for the coordination of the Constructors' work or schedules, or for any failure of any Constructor to comply with Laws and Regulations applicable to the performing and furnishing of its work. The Engineer (including RPR) neither guarantees the performances of any Constructor nor assumes responsibility for any Constructor's failure to furnish and perform the Work, or any portion of the Work, in accordance with the Construction Contract Documents. In addition, the specific terms set forth in Exhibit A, Paragraph A1.05, of this Agreement are applicable.
- C. The duties and responsibilities of the RPR are as follows:
 - 1. *General:* RPR's dealings in matters pertaining to the Work in general shall be with Engineer and Contractor. RPR's dealings with Subcontractors shall only be through or with the full knowledge and approval of Contractor. RPR shall generally communicate with Owner only with the knowledge of and under the direction of Engineer.
 - 2. *Schedules:* Review the progress schedule, schedule of Shop Drawing and Sample submittals, schedule of values, and other schedules prepared by Contractor and consult with Engineer concerning acceptability of such schedules.

Exhibit D - Resident Project Representative.

EJCDC® E-500, Agreement Between Owner and Engineer for Professional Services.

Copyright © 2014 National Society of Professional Engineers, American Council of Engineering Companies, and American Society of Civil Engineers. All rights reserved.

Page 1

3. *Conferences and Meetings:* Attend meetings with Contractor, such as preconstruction conferences, progress meetings, job conferences, and other Project-related meetings (but not including Contractor's safety meetings), and as appropriate prepare and circulate copies of minutes thereof.
4. *Safety Compliance:* Comply with Site safety programs, as they apply to RPR, and if required to do so by such safety programs, receive safety training specifically related to RPR's own personal safety while at the Site.
5. *Liaison:*
 - a. Serve as Engineer's liaison with Contractor. Working principally through Contractor's authorized representative or designee, assist in providing information regarding the provisions and intent of the Construction Contract Documents.
 - b. Assist Engineer in serving as Owner's liaison with Contractor when Contractor's operations affect Owner's on-Site operations.
 - c. Assist in obtaining from Owner additional details or information, when required for proper execution of the Work.
6. *Clarifications and Interpretations:* Receive from Contractor submittal of any matters in question concerning the requirements of the Construction Contract Documents (sometimes referred to as requests for information or interpretation—RFIs), or relating to the acceptability of the Work under the Construction Contract Documents. Report to Engineer regarding such RFIs. Report to Engineer when clarifications and interpretations of the Construction Contract Documents are needed, whether as the result of a Contractor RFI or otherwise. Transmit Engineer's clarifications, interpretations, and decisions to Contractor. ,
7. *Shop Drawings and Samples:*
 - a. Record date of receipt of Samples and Contractor-approved Shop Drawings.
 - b. Receive Samples that are furnished at the Site by Contractor, and notify Engineer of availability of Samples for examination.
 - c. Advise Engineer and Contractor of the commencement of any portion of the Work requiring a Shop Drawing or Sample submittal, if RPR believes that the submittal has not been received from Contractor, or has not been approved by Contractor or Engineer.
8. *Proposed Modifications:* Consider and evaluate Contractor's suggestions for modifications to the Drawings or Specifications, and report such suggestions, together with RPR's recommendations, if any, to Engineer. Transmit Engineer's response (if any) to such suggestions to Contractor.

9. *Review of Work; Defective Work:*

- a. Report to Engineer whenever RPR believes that any part of the Work is defective under the terms and standards set forth in the Construction Contract Documents, and provide recommendations as to whether such Work should be corrected, removed and replaced, or accepted as provided in the Construction Contract Documents.
- b. Inform Engineer of any Work that RPR believes is not defective under the terms and standards set forth in the Construction Contract Documents, but is nonetheless not compatible with the design concept of the completed Project as a functioning whole, and provide recommendations to Engineer for addressing such Work.
- c. Advise Engineer of that part of the Work that RPR believes should be uncovered for observation, or requires special testing, inspection, or approval.

10. *Inspections, Tests, and System Start-ups:*

- a. Consult with Engineer in advance of scheduled inspections, tests, and systems start-ups.
- b. Verify that tests, equipment, and systems start-ups and operating and maintenance training are conducted in the presence of appropriate Owner's personnel, and that Contractor maintains adequate records thereof.
- c. Observe, record, and report to Engineer appropriate details relative to the test procedures and systems start-ups.
- d. Observe whether Contractor has arranged for inspections required by Laws and Regulations, including but not limited to those to be performed by public or other agencies having jurisdiction over the Work.
- e. Accompany visiting inspectors representing public or other agencies having jurisdiction over the Work, record the results of these inspections, and report to Engineer.

11. *Records:*

- a. Maintain at the Site orderly files for correspondence, reports of job conferences, copies of Construction Contract Documents including all Change Orders, Field Orders, Work Change Directives, Addenda, additional Drawings issued subsequent to the execution of the Construction Contract, RFIs, Engineer's clarifications and interpretations of the Construction Contract Documents, progress reports, approved Shop Drawing and Sample submittals, and other Project-related documents.
- b. Prepare a daily report or keep a diary or log book, recording Contractor's hours on the Site, Subcontractors present at the Site, weather conditions, data relative to

questions of Change Orders, Field Orders, Work Change Directives, or changed conditions, Site visitors, deliveries of equipment or materials, daily activities, decisions, observations in general, and specific observations in more detail as in the case of observing test procedures; and send copies to Engineer.

- c. Upon request from Owner to Engineer, photograph or video Work in progress or Site conditions.
- d. Record and maintain accurate, up-to-date lists of the names, addresses, fax numbers, e-mail addresses, websites, and telephone numbers (including mobile numbers) of all Contractors, Subcontractors, and major Suppliers of materials and equipment.
- e. Maintain records for use in preparing Project documentation.
- f. Upon completion of the Work, furnish original set of all RPR Project documentation to Engineer.

12. *Reports:*

- a. Furnish to Engineer periodic reports as required of progress of the Work and of Contractor's compliance with the progress schedule and schedule of Shop Drawing and Sample submittals.
- b. Draft and recommend to Engineer proposed Change Orders, Work Change Directives, and Field Orders. Obtain backup material from Contractor.
- c. Furnish to Engineer and Owner copies of all inspection, test, and system start-up reports.
- d. Immediately inform Engineer of the occurrence of any Site accidents, emergencies, acts of God endangering the Work, possible force majeure or delay events, damage to property by fire or other causes, or the discovery of any potential differing site condition or Constituent of Concern.

13. *Payment Requests:* Review applications for payment with Contractor for compliance with the established procedure for their submission and forward with recommendations to Engineer, noting particularly the relationship of the payment requested to the schedule of values, Work completed, and materials and equipment delivered at the Site but not incorporated in the Work.

14. *Certificates, Operation and Maintenance Manuals:* During the course of the Work, verify that materials and equipment certificates, operation and maintenance manuals and other data required by the Contract Documents to be assembled and furnished by Contractor are applicable to the items actually installed and in accordance with the Contract Documents, and have these documents delivered to Engineer for review and forwarding to Owner prior to payment for that part of the Work.

15. *Completion:*

- a. Participate in Engineer's visits to the Site regarding Substantial Completion, assist in the determination of Substantial Completion, and prior to the issuance of a Certificate of Substantial Completion submit a punch list of observed items requiring completion or correction.
- b. Participate in Engineer's visit to the Site in the company of Owner and Contractor, to determine completion of the Work, and prepare a final punch list of items to be completed or corrected by Contractor.
- c. Observe whether all items on the final punch list have been completed or corrected, and make recommendations to Engineer concerning acceptance and issuance of the Notice of Acceptability of the Work (Exhibit E).

D. Resident Project Representative shall not:

1. Authorize any deviation from the Construction Contract Documents or substitution of materials or equipment (including "or-equal" items).
2. Exceed limitations of Engineer's authority as set forth in this Agreement.
3. Undertake any of the responsibilities of Contractor, Subcontractors, or Suppliers, or any Constructor.
4. Advise on, issue directions relative to, or assume control over any aspect of the means, methods, techniques, sequences or procedures of the Work, by Contractor or any other Constructor.
5. Advise on, issue directions regarding, or assume control over security or safety practices, precautions, and programs in connection with the activities or operations of Owner or Contractor.
6. Participate in specialized field or laboratory tests or inspections conducted off-site by others except as specifically authorized by Engineer.
7. Accept Shop Drawing or Sample submittals from anyone other than Contractor.
8. Authorize Owner to occupy the Project in whole or in part.

This is **EXHIBIT E**, consisting of 3 pages, referred to in and part of the **Agreement between Owner and Engineer for Professional Services** dated when signed by Owner.

ONLY APPLICABLE FOR CONSTRUCTION PHASE



ENGINEERS JOINT CONTRACT
DOCUMENTS COMMITTEE

NOTICE OF ACCEPTABILITY OF WORK

PROJECT:

OWNER:

CONTRACTOR:

OWNER'S CONSTRUCTION CONTRACT IDENTIFICATION:

EFFECTIVE DATE OF THE CONSTRUCTION CONTRACT:

ENGINEER:

NOTICE DATE:

To:

Owner

And To:

Contractor

From:

Engineer

The Engineer hereby gives notice to the above Owner and Contractor that Engineer has recommended final payment of Contractor, and that the Work furnished and performed by Contractor under the above Construction Contract is acceptable, expressly subject to the provisions of the related Contract Documents, the Agreement between Owner and Engineer for Professional Services dated _____, and the following terms and conditions of this Notice:

CONDITIONS OF NOTICE OF ACCEPTABILITY OF WORK

The Notice of Acceptability of Work ("Notice") is expressly made subject to the following terms and conditions to which all those who receive said Notice and rely thereon agree:

1. This Notice is given with the skill and care ordinarily used by members of the engineering profession practicing under similar conditions at the same time and in the same locality.
2. This Notice reflects and is an expression of the Engineer's professional opinion.
3. This Notice is given as to the best of Engineer's knowledge, information, and belief as of the Notice Date.
4. This Notice is based entirely on and expressly limited by the scope of services Engineer has been employed by Owner to perform or furnish during construction of the Project (including observation of the Contractor's work) under Engineer's Agreement with Owner, and applies only to facts that are within Engineer's knowledge or could reasonably have been ascertained by Engineer as a result of carrying out the responsibilities specifically assigned to Engineer under such Agreement.
5. This Notice is not a guarantee or warranty of Contractor's performance under the Construction Contract, an acceptance of Work that is not in accordance with the related Contract Documents, including but not limited to defective Work discovered after final inspection, nor an assumption of responsibility for any failure of Contractor to furnish and perform the Work thereunder in accordance with the Construction Contract Documents, or to otherwise comply with the Construction Contract Documents or the terms of any special guarantees specified therein.
6. This Notice does not relieve Contractor of any surviving obligations under the Construction Contract, and is subject to Owner's reservations of rights with respect to completion and final payment.

By: _____

Title: _____

Dated: _____

This is **EXHIBIT G**, consisting of 2 pages, referred to in and part of the **Agreement between Owner and Engineer for Professional Services** dated when signed by Owner.

Insurance

Paragraph 6.05 of the Agreement is supplemented to include the following agreement of the parties:

G6.05 Insurance

A. The limits of liability for the insurance required by Paragraph 6.05.A and 6.05.B of the Agreement are as follows:

1. By Engineer:

- a. Workers' Compensation: Statutory
- b. Employer's Liability --
 - 1) Bodily injury, each accident: \$500,000
 - 2) Bodily injury by disease, each employee: \$500,000
 - 3) Bodily injury/disease, aggregate: \$500,000
- c. General Liability --
 - 1) Each Occurrence (Bodily Injury and Property Damage): \$1,000,000
 - 2) General Aggregate: \$2,000,000
- d. Excess or Umbrella Liability --
 - 1) Per Occurrence: \$4,000,000
 - 2) General Aggregate: \$4,000,000
- e. Automobile Liability --Combined Single Limit (Bodily Injury and Property Damage):
\$1,000,000
- f. Professional Liability --
 - 1) Each Claim Made \$2,000,000
 - 2) Annual Aggregate \$2,000,000
- g. Other (specify): N/A

Exhibit G – Insurance.

2. By Owner:

- a. Workers' Compensation: Statutory
- b. Employer's Liability --
 - 1) Bodily injury, Each Accident \$ 0
 - 2) Bodily injury by Disease, Each Employee \$ 0
 - 3) Bodily injury/Disease, Aggregate \$ 0
- c. General Liability --
 - 1) General Aggregate: \$2,000,000
 - 2) Each Occurrence (Bodily Injury and Property Damage): \$1,000,000
- d. Excess Umbrella Liability
 - 1) Per Occurrence: \$ 0
 - 2) General Aggregate: \$ 0
- e. Automobile Liability – Combined Single Limit (Bodily Injury and Property Damage):
\$ 0
- f. Other (specify): N/A

B. Additional Insureds:

- 1. The following individuals or entities are to be listed on Owner's general liability policies of insurance as additional insureds:
 - a. DuBois & King, Inc.
Engineer
- 2. During the term of this Agreement the Engineer shall notify Owner of any other Consultant to be listed as an additional insured on Owner's general liability policies of insurance.
- 3. The Owner shall be listed on Engineer's general liability policy as provided in Paragraph 6.05.A.

This is EXHIBIT H, consisting of 1 pages, referred to in and part of the **Agreement between Owner and Engineer for Professional Services** dated when signed by Owner.

Dispute Resolution

Paragraph 6.09 of the Agreement is supplemented to include the following agreement of the parties:

H6.08 *Dispute Resolution*

- A. *Mediation*: Owner and Engineer agree that they shall first submit any and all unsettled claims, counterclaims, disputes, and other matters in question between them arising out of or relating to this Agreement or the breach thereof (“Disputes”) to mediation. Owner and Engineer agree to participate in the mediation process in good faith. The process shall be conducted on a confidential basis, and shall be completed within 120 days. If such mediation is unsuccessful in resolving a Dispute, then (1) the parties may mutually agree to a dispute resolution of their choice, or (2) either party may seek to have the Dispute resolved by a court of competent jurisdiction.

This is **EXHIBIT I**, consisting of 2 pages, referred to in and part of the **Agreement between Owner and Engineer for Professional Services** dated when signed by Owner.

Limitations of Liability

Paragraph 6.11 of the Agreement is supplemented to include the following agreement of the parties:

A. Limitation of Engineer's Liability

1. **Engineer's Liability Limited to Amount of Insurance Proceeds:** Engineer shall procure and maintain insurance as required by and set forth in Exhibit G to this Agreement. Notwithstanding any other provision of this Agreement, and to the fullest extent permitted by Laws and Regulations, the total liability, in the aggregate, of Engineer and Engineer's officers, directors, members, partners, agents, employees, and Consultants to Owner and anyone claiming by, through, or under Owner for any and all claims, losses, costs, or damages whatsoever arising out of, resulting from, or in any way related to the Project or the Agreement from any cause or causes, including but not limited to the negligence, professional errors or omissions, strict liability, breach of contract, indemnity obligations, or warranty express or implied, of Engineer or Engineer's officers, directors, members, partners, agents, employees, or Consultants (hereafter "Owner's Claims"), shall not exceed the total insurance proceeds paid on behalf of or to Engineer by Engineer's insurers in settlement or satisfaction of Owner's Claims under the terms and conditions of Engineer's insurance policies applicable thereto (excluding fees, costs and expenses of investigation, claims adjustment, defense, and appeal), up to the amount of insurance required under this Agreement. If no such insurance coverage is provided with respect to Owner's Claims, then the total liability, in the aggregate, of Engineer and Engineer's officers, directors, members, partners, agents, employees, and Consultants to Owner and anyone claiming by, through, or under Owner for any and all such uninsured Owner's Claims shall not exceed \$50,000.
2. **Exclusion of Special, Incidental, Indirect, and Consequential Damages:** To the fullest extent permitted by Laws and Regulations, and notwithstanding any other provision in the Agreement, consistent with the terms of Paragraph 6.11, the Engineer and Engineer's officers, directors, members, partners, agents, Consultants, and employees shall not be liable to Owner or anyone claiming by, through, or under Owner for any and all claims for or entitlement to special, incidental, indirect, or consequential damages arising out of, resulting from, or in any way related to this Agreement or the Project, from any cause or causes, including but not limited to any such damages caused by the negligence, professional causes, including but not limited to any such damages caused by the negligence, professional errors or omissions, strict liability, breach of contract, indemnity obligations, or warranty express or implied of Engineer or Engineer's officers, directors, members, partners, agents, or employees.

- B. **Indemnification by Owner:** To the fullest extent permitted by Laws and Regulations, Owner shall indemnify and hold harmless Engineer and its officers, directors, members,

Exhibit I - Limitations on Liability.

EJCDC® E-500, Agreement Between Owner and Engineer for Professional Services.

Copyright © 2014 National Society of Professional Engineers, American Council of Engineering Companies, and American Society of Civil Engineers. All rights reserved.

partners, agents, employees, and Consultants from and against any and all claims, costs, losses, and damages (including but not limited to all fees and charges of engineers, architects, attorneys, and other professionals, and all court, arbitration, or other dispute resolution costs) arising out of or relating to the Project, provided that any such claim, cost, loss, or damage is attributable to bodily injury, sickness, disease, or death or to injury to or destruction of tangible property (other than the Work itself), including the loss of use resulting therefrom, but only to the extent caused by any negligent act or omission of Owner or Owner's officers, directors, members, partners, agents, employees, consultants, or others retained by or under contract to the Owner with respect to this Agreement or to the Project.

This is **EXHIBIT J**, consisting of 1 pages, referred to in and part of the **Agreement between Owner and Engineer for Professional Services** dated when signed by Owner.

Special Provisions

This Agreement is amended to include the following agreement(s) of the parties:

None

This is **EXHIBIT K**, consisting of 2 pages, referred to in and part of the **Agreement between Owner and Engineer for Professional Services** dated when signed by Owner.

AMENDMENT TO OWNER-ENGINEER AGREEMENT
Amendment No. _____

The Effective Date of this Amendment is: _____.

Background Data

Effective Date of Owner-Engineer Agreement:

Owner:

Engineer:

Project:

Nature of Amendment: [Check those that are applicable and delete those that are inapplicable.]

- _____ Additional Services to be performed by Engineer
- _____ Modifications to services of Engineer
- _____ Modifications to responsibilities of Owner
- _____ Modifications of payment to Engineer
- _____ Modifications to time(s) for rendering services
- _____ Modifications to other terms and conditions of the Agreement

Description of Modifications:

Here describe the modifications, in as much specificity and detail as needed. Use an attachment if necessary.

Agreement Summary:

Original agreement amount:	\$ _____
Net change for prior amendments:	\$ _____
This amendment amount:	\$ _____
Adjusted Agreement amount:	\$ _____

Change in time for services (days or date, as applicable): _____

The foregoing Agreement Summary is for reference only and does not alter the terms of the Agreement, including those set forth in Exhibit C.

Owner and Engineer hereby agree to modify the above-referenced Agreement as set forth in this Amendment. All provisions of the Agreement not modified by this or previous Amendments remain in effect.

OWNER:

ENGINEER:

By: _____
Print _____
name: _____
Title: _____
Date Signed: _____

By: _____
Print _____
name: _____
Title: _____
Date Signed: _____

Media Log Report

Rev.01/26/12

From: 03/12/2020 7:29

To: 03/19/2020 2:15

Date/Time	Incident #	Call Type	Location
ORI: VT0120100 <u>Barre City Police Department</u>			
3/19/20 2:15	20BA002464	<i>Suspicious Event</i>	Washington St
3/18/20 23:32	20BA002463	<i>Noise</i>	Hunter Ave
Complaint of a barking dog off Hunter Ave.			
3/18/20 18:19	20BA002462	<i>Footpatrol</i>	N Main St
foot patrol down town with K9			
3/18/20 17:39	20BA002461	<i>Supervisory Duties - Case review</i>	Fourth
Supervisor Duties- Case Review			
3/18/20 17:02	20BA002460	<i>Needle Disposal</i>	Webster St
Needle Disposal on Webster St			
3/18/20 16:25	20BA002459	<i>Loitering / Vagrancy</i>	North Main Street
loitering/vagrancy N Main St			
3/18/20 15:43	20BA002458	<i>Animal Problem</i>	Skyline Dr
3/18/20 14:19	20BA002457	<i>Family Disturbance - Verbal</i>	Allen Street
family disturbance - verbal Allen St			
3/18/20 12:36	20BA002456	<i>Family Disturbance - Verbal</i>	South Main St
family disturbance - verbal S Main St			
3/18/20 12:14	20BA002455	<i>TRO/FRO Service</i>	Richardson Rd
3/18/20 9:00	20BA002454	<i>Prisoner - Lodging/Releasing</i>	Fourth St Barre, Vt 05641
prisoner release Barre City			
3/18/20 0:03	20BA002453	<i>Trespass</i>	W Second St
Male trespassing on private property off W. Second St.			
3/17/20 23:37	20BA002452	<i>Suspicious Event</i>	North Main St / First St
Male trespassing on private property off W. Second St			
3/17/20 22:58	20BA002451	<i>Domestic Disturbance</i>	North Main St
Disturbance reported on N Main St			
3/17/20 21:31	20BA002450	<i>Disturbance</i>	Maplewood Ave
Disturbance on Maplewood Ave.			
3/17/20 21:31	20BA002449	<i>Overdose</i>	Spaulding St
Overdose on Spaulding St			
3/17/20 20:46	20BA002448	<i>Prisoner</i>	Fourth Street
3/17/20 20:21	20BA002447	<i>Intoxication</i>	S Main Street
Intoxicated female taken into protective custody			
3/17/20 19:52	20BA002446	<i>Disorderly Conduct</i>	N Main street / Richardson
Subjects yelling at each other on N Main St			
3/17/20 19:17	20BA002445	<i>Disturbance</i>	Church St #
Report of a disturbance on church st			
3/17/20 18:41	20BA002444	<i>Assist - Public</i>	West Street

Media Log Report

Rev.01/26/12

From: 03/12/2020 7:29

To: 03/19/2020 2:15

Date/Time	Incident #	Call Type	Location
ORI: VT0120100 <u>Barre City Police Department</u>			
Public assist at PD			
3/17/20 18:38	20BA002443	Animal Problem	Hope Cemetary
Animal issue in Hope Cemetery			
3/17/20 18:27	20BA002442	Disorderly Conduct	Church Street
Disorderly male at City Hall Park			
3/17/20 17:39	20BA002441	Suspicious Event	Fourth Street
Suspicious activity reported at the PD			
3/17/20 17:12	20BA002440	Loitering / Vagrancy	S Main St
Report of loitering at Basil's			
3/17/20 16:59	20BA002439	Vandalism	Camp Street
report of a vandalism on camp st			
3/17/20 15:37	20BA002438	Disorderly Conduct	Averill St / Church St
3/17/20 15:07	20BA002437	Custodial Interference - NonRep	Summer Street
custodial interference Summer St			
3/17/20 14:45	20BA002436	Domestic Disturbance	Prospect Street
Assault on Prospect Street.			
3/17/20 12:25	20BA002435	Prisoner - Lodging/Releasing	Fourth St
prisoner release Barre City			
3/17/20 12:05	20BA002434	Threats/Harassment	Eastern Ave
3/17/20 11:32	20BA002433	Assist - Other	North Main St
assist			
3/17/20 10:37	20BA002432	Prisoner	Fourth St
3/17/20 10:35	20BA002431	Prisoner - Lodging/Releasing	Fourth St
3/17/20 9:03	20BA002430	Prisoner - Lodging/Releasing	Fourth St
prisoner release Barre City			
3/17/20 8:03	20BA002429	Assist - Other	North Main St
3/17/20 6:57	20BA002428	Threats/Harassment	Jiffy Mart
Male threatening people on North Main St.			
3/17/20 5:35	20BA002427	Noise	Church St
Male threatening people on North Main St.			
3/17/20 3:07	20BA002426	Noise	Eastern Ave
3/17/20 0:39	20BA002425	Suspicious Event	Pearl St
Broken window at Downtown Rentals			
3/16/20 21:59	20BA002424	Disorderly Conduct	Fourth Street
Disorderly male at police department.			

Media Log Report

Rev.01/26/12

From: 03/12/2020 7:29**To:** 03/19/2020 2:15

Date/Time	Incident #	Call Type	Location
ORI: VT0120100 Barre City Police Department			
3/16/20 21:10	20BA002423	<i>Prisoner</i>	Fourth Street
3/16/20 20:54	20BA002422	<i>Disorderly Conduct</i>	Church Street
Disorderly male on Church Street.			
3/16/20 19:59	20BA002421	<i>Assist - Public</i>	Summer Street
Public assist on Summer St			
3/16/20 19:28	20BA002420	<i>Disturbance</i>	City Hall Park
Disorderly Male in City Hall Park.			
3/16/20 19:12	20BA002419	<i>Motor Vehicle Complaint</i>	Tremont St / Camp Street
Motor vehicle complaint on Tremont St			
3/16/20 18:39	20BA002418	<i>Property - Found</i>	City Hall Park
Found property at City Hall Park.			
3/16/20 17:33	20BA002417	<i>Welfare Check</i>	Washington Street
Welfare Check on Washington Street			
3/16/20 17:16	20BA002416	<i>Assist - Public</i>	Fourth Street
Public assist at PD			
3/16/20 17:05	20BA002415	<i>Supervisory Duties - Case review</i>	Fourth
Supervisor Duties- Case Review			
3/16/20 15:41	20BA002414	<i>Trespass</i>	South Main St
Trespassing complaint on S. Main Street.			
3/16/20 15:18	20BA002413	<i>Vandalism</i>	Summer st / Jerry's sports tavern
Vandalism reported			
3/16/20 14:15	20BA002412	<i>Prisoner</i>	Fourth St
3/16/20 14:13	20BA002411	<i>Prisoner - Lodging/Releasing</i>	Fourth St
protective custody N Main St			
3/16/20 13:56	20BA002410	<i>Intoxication</i>	North Main St
Intoxicated male on N. Main Street.			
3/16/20 13:36	20BA002409	<i>Assist - Agency</i>	Ayers St
Union 32 calls SHS for a welfare check			
3/16/20 13:28	20BA002408	<i>Intoxication</i>	North Main St
Intoxicated male on N. Main Street.			
3/16/20 12:41	20BA002407	<i>Prisoner - Lodging/Releasing</i>	Fourth St
Released prisoner on N. Main Street.			
3/16/20 12:33	20BA002406	<i>Suspicious Event</i>	Bank Street
Suspicious event reported on bank St.			
3/16/20 12:28	20BA002405	<i>VIN verification</i>	Elmwood Ave
VIN check on Elmwood Ave.			
3/16/20 10:44	20BA002404	<i>Suspicious Event</i>	Ayers St
3/16/20 10:00	20BA002403	<i>Alarm - Security</i>	South Main St

Media Log Report

Rev.01/26/12

From: 03/12/2020 7:29

To: 03/19/2020 2:15

Date/Time	Incident #	Call Type	Location
ORI: VT0120100		<u>Barre City Police Department</u>	
False alarm at Cumberland farms on S. Main St.			
3/16/20 9:36	20BA002402	Assist - Agency	North Main St
Paperwork to court.			
3/16/20 8:46	20BA002401	Welfare Check	Averill St
Welfare check on a child on Averill St.			
3/16/20 8:13	20BA002400	Supervisory Duties - Case review	4th Street
3/16/20 8:00 20BA002399 Assist - Public			
Public assist N Main St			
3/16/20 7:55	20BA002398	Training-In-Service	Wales St / Washington St
3/16/20 4:08 20BA002397 Trespass			
Trespass violation on Church St.			
3/15/20 23:49	20BA002396	Intoxication	Washington St
Subject passed out in hallway on Church St			
3/15/20 23:19	20BA002395	Larceny - Retail Theft	N Main St
Subject stole toilet paper out of the bathroom at N Main St Cumberland Farms			
3/15/20 22:34	20BA002394	Assault - Simple	Hill Street
Simple Assault on Hill Street			
3/15/20 22:16	20BA002393	Motor Vehicle Complaint	Prospect Street
Motor vehicle complaint on Prospect Street.			
3/15/20 21:42	20BA002392	Juvenile Problem	Maple Avenue
Juvenile problem on maple ave			
3/15/20 17:46	20BA002391	Supervisory Duties - Case review	Fourth
Supervisor Duties- Case Review			
3/15/20 17:38	20BA002390	Threats/Harassment	N Main Street
Suspicious Event on North Main Street			
3/15/20 17:32	20BA002389	Animal Problem	Newton St
Lost Dog on Newton Street			
3/15/20 16:33	20BA002388	Threats/Harassment	Elm St
Verbal altercation on N. Main Street.			
3/15/20 16:21	20BA002387	Trespass	N Main Street
Trespassing on N. Main Street.			
3/15/20 14:08	20BA002386	Suspicious Event	South Main St
Trespassing complaint at the Tilden House.			
3/15/20 12:55	20BA002385	TRO/FRO Service	Howard St
Agency assist.			
3/15/20 11:27	20BA002384	Disturbance	North Main St
Disturbance on N. Main Street.			
3/15/20 11:01	20BA002383	Suspicious Person	North Main St #

Media Log Report

Rev.01/26/12

From: 03/12/2020 7:29

To: 03/19/2020 2:15

Date/Time	Incident #	Call Type	Location
ORI: VT0120100 <u>Barre City Police Department</u>			
Suspicious person on N. Main Street.			
3/15/20 10:49	20BA002382	Alarm - Security	South Main St
Alarm at South Main Cumberland Farms.			
3/15/20 9:02	20BA002381	Prisoner - Lodging/Releasing	Fourth St
Released prisoner. N Main St			
3/15/20 9:01	20BA001975	Prisoner - Lodging/Releasing	4th Street
Prisoner release.			
3/15/20 8:11	20BA002380	Assist - Agency	North Main St
Meals for prisoners. N Main St			
3/15/20 5:04	20BA002379	Alarm - Security	North Main St
Security alarm on N Main St			
3/15/20 0:48	20BA002378	Animal Problem	S Main St
Animal problem on S Main St			
3/15/20 0:43	20BA002377	Traffic Stop	Pleasant St
Traffic stop for failure to signal on Pleasant St			
3/14/20 23:22	20BA002376	Prisoner	Fourth St
3/14/20 23:21	20BA002375	Prisoner - Lodging/Releasing	Fourth St
Prisoner lodged at BCPD			
3/14/20 23:03	20BA002374	Juvenile Problem	Batchelder St
3/14/20 23:03	20BA002373	Intoxication	Washington St
Report of a subject yelling at overflow shelter on Church St, subject taken into protective custody and cited into court			
3/14/20 22:19	20BA002372	Assist - Agency	Berlin St
Agency assist			
3/14/20 22:15	20BA002371	Juvenile Problem	Green Acres
juvenile problem at Green Acres			
3/14/20 21:43	20BA002370	Juvenile Problem	Green Acres
juvenile problem at Green Acres			
3/14/20 21:35	20BA002369	Traffic Stop	N Main street / City Hall Park
Traffic stop for defective equipment on N Main st			
3/14/20 21:30	20BA002368	Prisoner	Fourth St
3/14/20 21:25	20BA002367	Prisoner - Lodging/Releasing	Fourth St
3/14/20 21:05	20BA002366	Assist - Other	Brooklyn St
Intoxicated person Brooklynn Street			
3/14/20 20:18	20BA002365	Prisoner	4th St
3/14/20 20:17	20BA002364	Prisoner - Lodging/Releasing	Fourth St

Media Log Report

Rev.01/26/12

From: 03/12/2020 7:29**To:** 03/19/2020 2:15

Date/Time	Incident #	Call Type	Location
ORI: VT0120100		<u>Barre City Police Department</u>	
3/14/20 19:47	20BA002363	TRO/FRO Violation	Washington Street
Tro violation on Washington St			
3/14/20 19:32	20BA002362	Traffic Stop	S Main St / Mill St
Traffic stop for defective equipment on S Main St			
3/14/20 17:15	20BA002361	Intoxication	Pearl St
Intoxicated male behind Bonacorsi.			
3/14/20 17:08	20BA002360	Suspicious Person	N Main Street
Suspicious Person on N Main St			
3/14/20 16:58	20BA002359	Assist - Other	East Parkside Terrace
Public assist on East Parkside Terr			
3/14/20 14:42	20BA002358	Suspicious Event	West Street
Suspicious event on West Street.			
3/14/20 13:49	20BA002357	Fire - Alarm Activation	Onward Street
Fire-Alarm Activation on Onward Street			
3/14/20 11:59	20BA002356	Accident - Property damage only	Bailey Street
Accident on Bailey Street			
3/14/20 10:14	20BA002355	Assist - Public	Highgate Drive
Public assist at Highgate Apartments.			
3/14/20 10:07	20BA002354	Disturbance	Washington Street
Disturbance on Washington Street.			
3/14/20 9:29	20BA002353	Assist - Public	Fourth Street
Assist-Public on Fourth Street			
3/14/20 9:20	20BA002352	Alarm - Security	Washington Street
Alarm on Washington Street			
3/14/20 9:10	20BA002351	Prisoner - Lodging/Releasing	Fourth Street
Prisoner release on Fourth Street			
3/14/20 9:06	20BA002350	Transport - Prisoner	Fourth Street
Prisoner transport to 4C's			
3/14/20 8:58	20BA002349	VIN verification	Fourth Street
Vin verification on Fourth Street			
3/14/20 7:45	20BA002348	Welfare Check	Second St
Welfare check on Second Street			
3/14/20 3:19	20BA002347	TRO/FRO Service	Palmisano Plaza
TRO service on Palmisano Plaza			
3/14/20 2:19	20BA002346	Prisoner	Fourth St
Prisoner Lodging on Fourth Street.			
3/14/20 2:15	20BA002345	Prisoner - Lodging/Releasing	Fourth St
Prisoner Lodging on Fourth Street.			
3/14/20 0:46	20BA002344	Noise	Eastern Ave

Media Log Report

Rev.01/26/12

From: 03/12/2020 7:29

To: 03/19/2020 2:15

Date/Time	Incident #	Call Type	Location
ORI: VT0120100 Barre City Police Department			
Noise Complaint and underage Marijuana Possession on Eastern Ave.			
3/14/20 0:25	20BA002343	Domestic Disturbance	Palmisano Plaza
Domestic issue handled via phone			
3/13/20 23:32	20BA002342	Prisoner - Lodging/Releasing	Fourth St
Assisted Berin PD with collecting bail and releasing prisoner			
3/13/20 23:25	20BA002341	Disorderly Conduct	Church St
3/13/20 23:06	20BA002340	Disorderly Conduct	Church St
Disorderly conduct reported on Church St.			
3/13/20 21:51	20BA002339	Prisoner	Fourth St
3/13/20 21:21	20BA002338	Assist - Other	High Holborn
3/13/20 21:10	20BA002337	Disturbance	Andrews Court
Domestic Disturbance on Andrews Court			
3/13/20 20:14	20BA002336	Domestic Disturbance	S Main St
Domestic disturbance at the Hollow Inn			
3/13/20 20:03	20BA002335	Traffic Stop	Allen St / Green Acres
Traffic stop for speed on Allen St.			
3/13/20 19:55	20BA002334	Traffic Stop	North Main St / Second St
Traffic Stop for a broken headlight on North Main Street			
3/13/20 19:53	20BA002333	Arrest Warrant - In State	Fourth St
3/13/20 18:39	20BA002332	Assist - Public	Bank St
3/13/20 18:30	20BA002331	Fraud	Zan St
3/13/20 18:23	20BA002330	Accident - Property damage only	Circle St
3/13/20 18:18	20BA002329	Traffic Stop	South Main St #
Traffic stop for speed on S. Main St.			
3/13/20 17:52	20BA002328	Traffic Stop	Allen St
Traffic stop for speed on Allen St.			
3/13/20 17:50	20BA002327	Welfare Check	Blackwell St
Welfare Check on Blackwell Street			
3/13/20 17:32	20BA002326	Mental Health Issue	Pearl St
Mental Health Issue on Pearl Street.			
3/13/20 16:17	20BA002325	Disturbance	Seminary St
disturbance Seminary St			
3/13/20 14:58	20BA002324	Sex Offender Compliance Check	N Main Street
SOR compliance check Barre City			

Media Log Report

Rev.01/26/12

From: 03/12/2020 7:29

To: 03/19/2020 2:15

Date/Time	Incident #	Call Type	Location
ORI: VT0120100		<u>Barre City Police Department</u>	
3/13/20 14:47	20BA002323	Traffic Stop	Summer Street
Traffic Stop on Summer Street			
3/13/20 13:30	20BA002322	Assist - Other	Fourth Street
assist other Barre City			
3/13/20 12:14	20BA002321	Assist - Agency	Fourth Street
3/13/20 12:11	20BA002320	Assist - Public	Fourth St
Property release.			
3/13/20 12:05	20BA002319	Fraud	N Main Street
Fraud on North Main Street.			
3/13/20 11:11	20BA002318	Accident - Property damage only	Summer St / Merchant St
Accident on Summer Street			
3/13/20 11:05	20BA002317	Assist - Public	Granite St / Old Labor Hall
public assist Granite St			
3/13/20 10:42	20BA002316	Prisoner - Lodging/Releasing	Fourth St
Prisoner release.			
3/13/20 10:40	20BA002315	Prisoner - Lodging/Releasing	Fourth St
Prisoner release.			
3/13/20 8:30	20BA002314	Motor Vehicle Complaint	Ayers St #
Vehicle driving fast on Ayers Street			
3/12/20 22:21	20BA002313	Suicide - Attempted	Harrington Ave
3/12/20 22:14	20BA002312	Prisoner - Lodging/Releasing	Fourth St
3/12/20 21:39	20BA002311	Domestic Disturbance	South Main St
Domestic Disturbance on South Main Street.			
3/12/20 19:43	20BA002310	Violation of Conditions of Release	N Main St
3/12/20 19:41	20BA002309	Traffic Stop	North Main St #
Traffic Stop for a broken headlight on North Main Street			
3/12/20 18:51	20BA002308	Suspicious Event	Kirk Street
Building check of an unsecured residence on Kirk Street			
3/12/20 18:43	20BA002307	Assist - Other	Washington St
3/12/20 18:03	20BA002306	Prisoner	Fourth St
3/12/20 17:46	20BA002305	Motor Vehicle Complaint	North Main St.
Motor vehicle complaint on N. Main St.			
3/12/20 17:44	20BA002304	Needle Disposal	Washington St
Needle Disposal on Washington Street.			
3/12/20 17:09	20BA002303	Alarm - Security	N Main St

Media Log Report

Rev.01/26/12

From: 03/12/2020 7:29

To: 03/19/2020 2:15

Date/Time	Incident #	Call Type	Location
ORI: VT0120100		<u>Barre City Police Department</u>	
Alarm on North Main Street			
3/12/20 17:00	20BA002302	Missing Person	Summer St / Elm St
Missing juvenile located off Spaulding St.			
3/12/20 16:24	20BA002301	Disturbance	Summer St
Domestic Disturbance on Summer Street			
3/12/20 15:56	20BA002300	Threats/Harassment	North Main St #
threats/harassment Barre City			
3/12/20 14:42	20BA002299	Motor Vehicle Complaint	N Main St / Richardson Rd
mv complaint n main st			
3/12/20 14:02	20BA002298	Suspicious Event	Washington St
Suspicious Event on Washington Street			
3/12/20 13:53	20BA002297	VIN verification	Fourth St
vin check barre city			
3/12/20 13:51	20BA002296	Suspicious Event	N Main St / Subway Walk Thru
Suspicious Event on North Main Street.			
3/12/20 13:45	20BA002295	Prisoner	Fourth St
3/12/20 13:41	20BA002294	Suspicious Event	Washington St
Suspicious Event on Washington Street.			
3/12/20 13:20	20BA002293	Court Ordered Prints/Photos	Fourth St
Agency assist.			
3/12/20 12:57	20BA002292	Prisoner - Lodging/Releasing	Fourth St
prisoner lodging Barre City			
3/12/20 12:57	20BA002291	Prisoner	Fourth St
3/12/20 12:56	20BA002290	Prisoner - Lodging/Releasing	Fourth St
Prisoner Lodging on Fourth Street			
3/12/20 10:03	20BA002289	TRO/FRO Violation	Perry St
TRO violation Perry Street			
3/12/20 9:46	20BA002288	Court Ordered Prints/Photos	Fourth St
Court Order Prints/Photos on Fourth Street			
3/12/20 8:29	20BA002287	Drugs - Sale	Barre City Police
3/12/20 8:07	20BA002286	Suspicious Person	Ayers St
3/12/20 8:02	20BA002285	Assist - Other	N Main St
assist other n main st			
3/12/20 7:44	20BA002284	Assist - Other	4th Street
assist other Barre City			
3/12/20 7:29	20BA002283	Prisoner - Lodging/Releasing	Fourth St Barre, Vt 05641
prisoner release Barre City			

Media Log Report

Rev.01/26/12

From: 03/12/2020 7:29

To: 03/19/2020 2:15

Date/Time	Incident #	Call Type	Location
------------------	-------------------	------------------	-----------------

Total Incidents **183**

BARRE

Copy of Departmental Activity Report

Current Period: 03/12/20 to 03/18/20, Prior Period: 03/05/20 to 03/11/20

00:00 to 24:00

All Stations

All Shifts

All Units

All Activity Types

Category	Current Period		Prior Period	
	Count	Staff Hrs	Count	Staff Hrs
Dispatch/Remote Station Incidents*				
EMS Incidents	0	0.00	0	0.00
NFIRS Incidents	0	0.00	0	0.00
	0	0.00	0	0.00
Fire Alarm Situations				
Chemical release, reaction, or toxic condition	0	0.00	2	8.35
Combustible/flammable spills & leaks	2	8.75	0	0.00
Dispatched and cancelled en route	2	0.31	0	0.00
Emergency medical service (EMS) Incident	29	45.23	31	58.60
Excessive heat, scorch burns with no ignition	0	0.00	1	3.18
Outside rubbish fire	1	0.26	0	0.00
Rescue or EMS standby	0	0.00	5	23.42
Rescue, emergency medical call (EMS), other	0	0.00	1	0.87
Structure Fire	0	0.00	1	36.56
Unintentional system/detector operation (no fire)	1	1.88	3	4.81
Wrong location, no emergency found	0	0.00	1	0.45
	35	56.43	45	136.24
Hydrant Activities				
Flow Tests	0	0.00	0	0.00
Inspections	0	0.00	0	0.00
	0	0.00	0	0.00
Non-Incident Activities				
BURN PERMIT ISSUED	1	0.10	0	0.00
CLEAN INTERIOR	0	0.00	2	4.00
COMP TIME USED	0	0.00	1	12.00
DAY SHIFT COVERAGE	1	12.00	0	0.00
DEPARTMENTAL MEETING	5	3.75	0	0.00
DETAILING APPARATUS	3	3.75	0	0.00
NIGHT SHIFT COVERAGE	2	24.00	0	0.00
ON DUTY	24	564.00	25	586.00
PERSONAL TIME USED	0	0.00	1	2.00
SHARPS PICK UP	2	0.30	0	0.00

* Staff hours for Fire Alarm responses that have an associated EMS alarm record are considered shared hours. Shared hours are posted only with the EMS alarm responses to avoid duplication of staff hours in totals.

BARRE

Copy of Departmental Activity Report

Current Period: 03/12/20 to 03/18/20, Prior Period: 03/05/20 to 03/11/20

00:00 to 24:00

All Stations

All Shifts

All Units

All Activity Types

Category	Current Period		Prior Period	
	Count	Staff Hrs	Count	Staff Hrs
Non-Incident Activities				
SICK TIME USED	3	72.00	1	24.00
U 1 - OUT OF SERVICE	2	48.00	0	0.00
VACATION USED	1	24.00	2	48.00
WASH VEHICLES	0	0.00	2	1.00
	44	751.90	34	677.00
Occupancy Inspections/Activities				
ALARM TESTING/MAINTENANCE	4	0.08	0	0.00
FIRE DRILL	0	0.00	1	0.00
	4	0.08	1	0.00
Training				
AIRWAY MANAGEMENT	0	0.00	4	4.00
EMS SAFETY	1	1.00	0	0.00
MCI	0	0.00	2	0.00
MED DRAWS AND PUSHES	0	0.00	6	6.00
PEDIATRIC EMERGENCY	0	0.00	4	4.00
Triage	0	0.00	2	7.00
	1	1.00	18	21.00

* Staff hours for Fire Alarm responses that have an associated EMS alarm record are considered shared hours. Shared hours are posted only with the EMS alarm responses to avoid duplication of staff hours in totals.